

High Power 850/980/1060 Fiberoptic Isolator (up to 5W CW)

(patent pending)

Product Description

The OI Series High Power Optical Isolator is designed for high power applications by guiding light in the normal direction while block back reflection the reverse direction. With Agiltron's proprietary in-fiber beam expansion technology that scale down the power density, these components can intrinsic handle optical power beyond 20W. With our proprietary magnetic-optics technology and proven advanced micro optics design, it features low insertion loss, high isolation, compact structure, and high stability. They are tested under high power before shipping. This product has leading industrial performance. The OI isolator can be made using a variety of fibers including HI980, HI1060, LMA and other double cladding fibers. Customized designs are available to meet special applications.



Performance Specifications

OI Series	Min	Typical	Max	Unit
Operation Wavelength	840	850	860	nm
	970	980	990	
	1050	1060	1070	
Insertion Loss ³		0.8	1.2	dB
Wavelength Dependent Loss			0.2	dB
Isolation ²	25	30		
Polarization Dependent Loss (PI only)		0.1	0.2	dB
Polarization Mode Dispersion (PI only)			0.2	ps
Extinction Ratio (PM only)	20	25		
Return Loss	50			dB
Optical Power Handling	Up to 5			W ¹
Storage Temperature	-10		60	°C
Fiber Type	See order information			
Package Dimension	(L)61x(W)34x(H)33			mm

Note: 1 continue power level. For pulse application, please call.

2 Back Reflect<10%. For>10% application, please call us.

3. Excluding connectors.

Features

- Low Insertion Loss
- High Isolation
- High Stability
- High Reliability
- High Power
- Cost Effective

Applications

- Optical Fiber Amplifier
- Pump Laser Source
- Fiber Optic Sensor
- Test and Measurement
- Instrumentation

High Power 850/980/1060 Fiberoptic Isolator (up to 5W CW)

Optical Performance

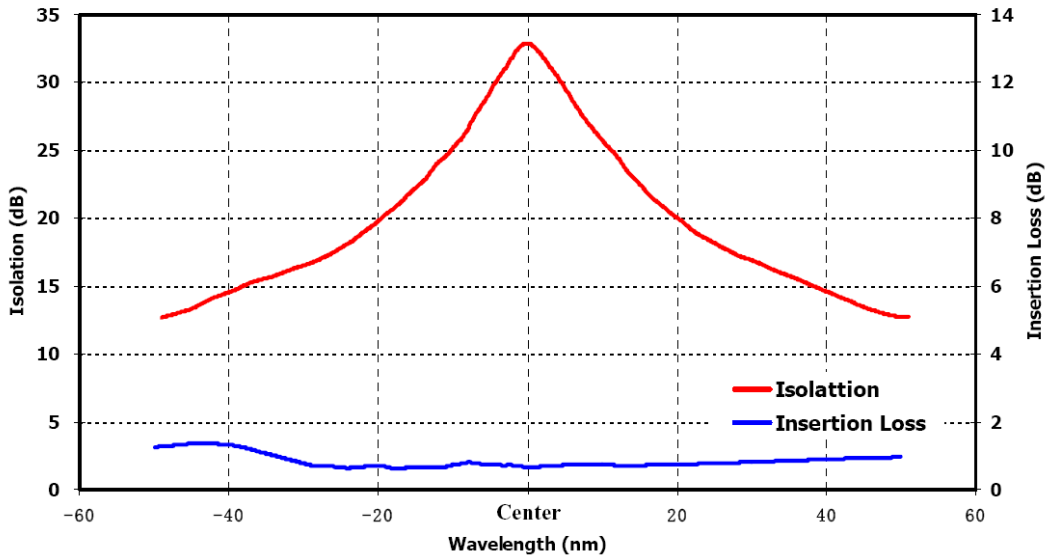

IL/Iso Vs. Temp @ Center Wavelength

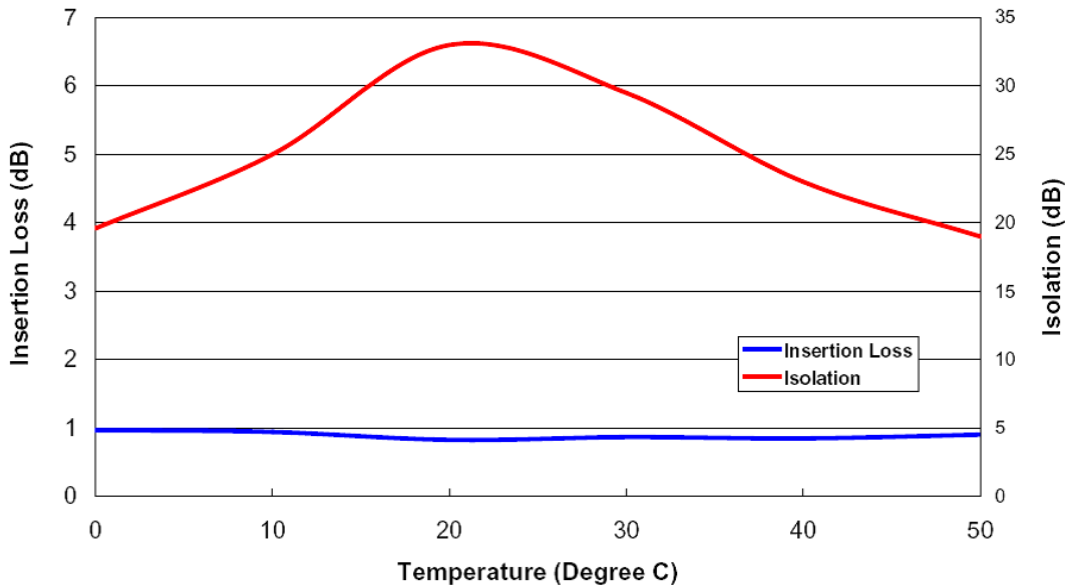

High Power 850/980/1060 Fiberoptic Isolator (up to 5W CW)

Mechanical Dimensions (Unit:mm)

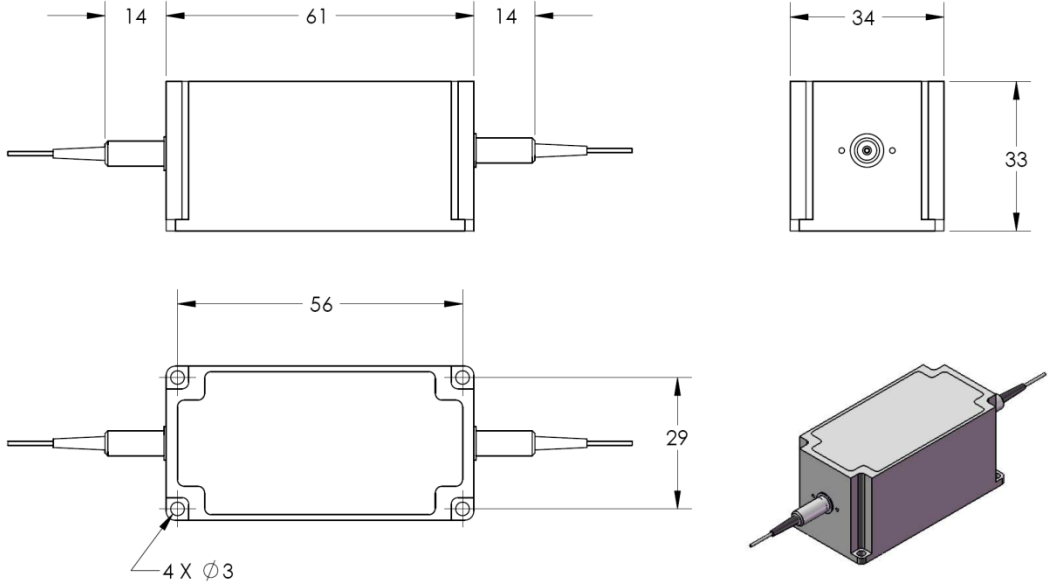

Ordering Information

OIST-	Type	Wavelength	Grade	Package	Fiber Type	Fiber Length	Connector
<input type="checkbox"/> <input type="checkbox"/>	<input type="checkbox"/>	<input type="checkbox"/>	<input type="checkbox"/>	<input type="checkbox"/>	<input type="checkbox"/>	<input type="checkbox"/>	1*
	HP Polarization Independent = 31 HP Polarization Maintaining = 32 Special = 30	1060 = 1 1030 = 3 980 = 9 850 = 8 Special = 0	1W = 1 2W = 2 5W = 5	Standard = 1 Special = 0	HI1060 = 2 HI980 = 9 PM980 = E Special = 0	Bare fiber = 1 900um Loose tube = 3 Special = 0	0.25M = 1 0.5M = 2 1.0M = 3 Special = 0

* Agiltron can provide a high power connector, please call.