



A Photonwares Company

15 Presidential Way
Woburn, MA 01801
Tel: 781-935-1200
Fax: 781-935-2040
www.agiltron.com

MSA C-Band Booster EDFA with 20/30dB Gain

User Manual

P/N: EDFA-1(2)CxM(H)xxxxxxx

Version: 2025 - 12



1 Ambient Parameters

Parameter	Min.	Typical	Max.	Unit	Note
Working Temperature	-5		55	°C	
Storage Temperature	-40		85	°C	
Working Relative Humidity	15		85	%	40°C non-condensation
Storage Relative Humidity	10		90	%	

2 Optical Parameters

Parameter	Min	Typical	Max	Unit	Note
Return Loss	45	-	-	dB	
Input & Output Fiber type	SMF-28e, 900um white loose tube			-	
Output Fiber Length	99	100	101	cm	100 ± 1cm, without connector
Input Fiber Length	99	100	101	cm	100 ± 1cm, without connector
Input & Output Fiber Connector Type	FC/APC			-	
Module Dimension	(W*L*H)90*70*15			mm	
Working Mode	AGC				
No Optical Power Report	-60			dBm	
Output power stability	-	-	±0.1	dB	
Accuracy of power reporting	-	-	±0.5	dB	
Gain control accuracy	-	-	±0.5	dB	
Output Power control accuracy	-	-	±0.5	dB	
Input & Output Isolation	-	35	-	dB	
In & Out Pump Leakage	-	-	-30	dBm	
PDG	-	-	0.5	dB	
PMD	-	-	0.5	ps	
CD	-	-	±5	ps/nm	
Multipath interference	-	-	-40	dB	

Operating Wavelength	1528	-	1565	nm	
Input Power Range	-30	-	10	dBm	
Gain	20	20/ 30	33	dB	Flatness<2.0 Gain adjustable range is ±1.5dB. Accuracy of normal temperature gain setting is 0.1dB.
Max Output Power	10 - 24			dBm	Varies by model
Input @ Typical	-10			dBm	
NF	-	5.5	6	dB	@Gain=20dB
GF	-	1	1.5	dB	@In=-3dBm, G=20dB
Input Power Alarm Threshold	-33	-31	-10	dBm	Settable range -33 ~ -10 dBm, Upward hysteresis 1dB, <-33dBm reporting no optical power
Output Power Alarm Threshold	-8	-6	23	dBm	Settable range -8 ~ +20.5, Upward hysteresis 1dB, <-8 reporting no optical power

Pump off threshold	-33	-33	-10	dBm	Settable range -33~-5, Upward hysteresis 1dB
APC Output power setting range	-5	-	20	dBm	Setting accuracy is 0.1dB
Default temperature alarm threshold	-5	70	70	°C	Settable range -5~+70°C Upward hysteresis 1°C
Ports	-	2	-	-	Input & output

3 Electrical Indicators

3.1 Power Supply:

Parameter	Min	Typical	Max	Unit	Note
Voltage	4.75	5.0	5.25	V	
Current	-	-	3.0	A	
Power Consumption	-	-	15	W	

3.2 Pin definition

3.2.1 Communication Port

Type: 34Pin 2.00mm intervals male socket CJT A2005WV-N-2x17P

3.2.2 Pin definition:

Pin No.	Name	Attribute	Level Type
1	NC	F	
2	NC	F	
3	+5V	P	
4	+5V	P	
5	+5V	P	
6	+5V	P	
7	GND	P	
8	GND	P	
9	NC	F	
10	NC	F	
11	GND	P	
12	GND	P	
13	NC	F	
14	NC	F	
15	NC	F	
16	NC	F	
17	NC	F	
18	NC	F	
19	NC	F	
20	NC	F	
21	NC	F	
22	NC	F	
23	GND	P	
24	GND	P	
25	Serial Port Input	I	LVTTL
26	Serial Port Output	O	LVTTL
27	GND	P	
28	GND	P	
29	+5V	P	
30	+5V	P	
31	+5V	P	
32	+5V	P	
33	NC	F	
34	NC	F	

* P: Power, I: Input, O: Output, F: None

4 Serial Port Communication Protocol

Parameter	Value	Unit
Baud rate	9600	Bit/s
Data bit	8	Bit
Stop bit	1	Bit
Parity bit	None	

5 Module Dimensions

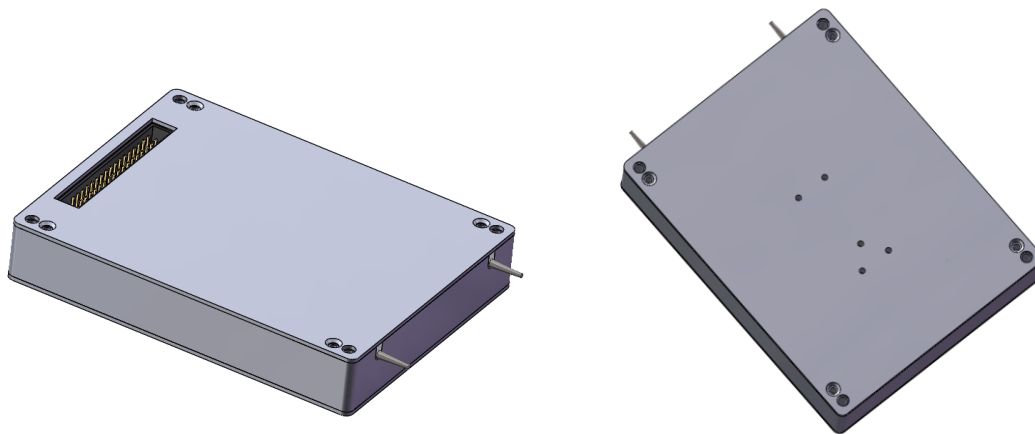
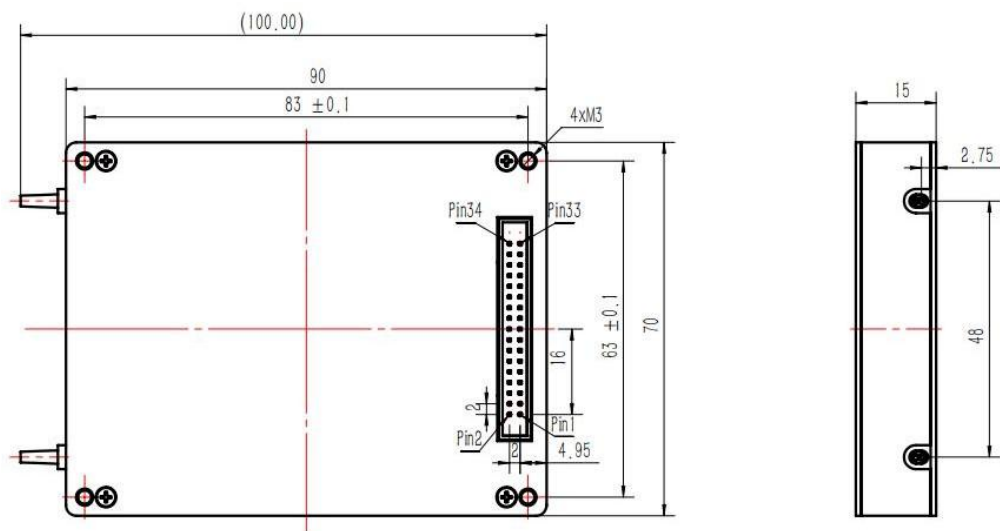

Figure 1 Mechanical drawing

6 Application Notes

- RS232-to-USB converting needs to be done by user. FTDI chip is recommended.
 - * Benchtop is available at <https://agiltron.com/>.
 - * RS232-to-USB converting PCB is also available at <https://agiltron.com/>.
- Upon accomplishment of the above EDFA can be remotely controlled by UART commands or the 'EDFA GUI' program (EDFA-L option) provided.
- Heatsink is needed for this EDFA, as shown below.

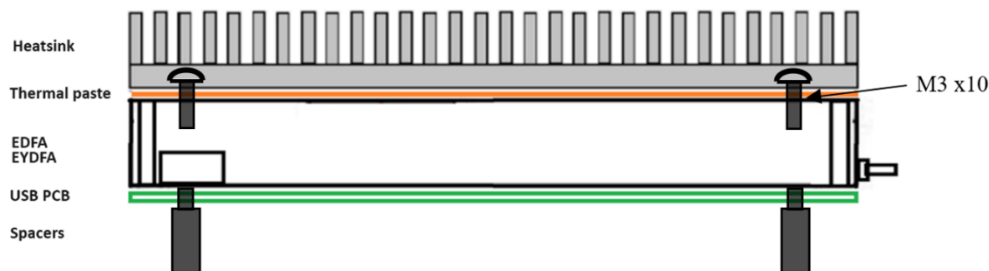

Figure 2 Heatsink installation

7 Software Instruction

Note:

USB to COM driver for FTDI devices needs to be installed on the computer for remote control. The driver can be downloaded from <https://ftdichip.com/drivers/vcp-drivers/>.

- 1) Download GUI software 'EDFA GUI V3.0' from the link below, under Step File/GUI.

<https://agiltron.com/product/erbium-doped-fiber-amplifier-module/>

A copy of GUI also comes with EDFA.



Figure 3 Download link of driver

- 2) Run setup.exe to install the GUI on host computer.
- 3) Power on EDFA.
- 4) Connect host computer to EDFA by using a USB cable.
- 5) Run EDFA GUI V3.0.
- 6) Choose device model EDFA-L.
 - EDFA-H: standard version EDFAs with 23dBm or higher output power.
 - **EDFA-L**: standard version EDFAs with less than 23dBm output power.

- EDFA-C: high-end or special version EDFAs.

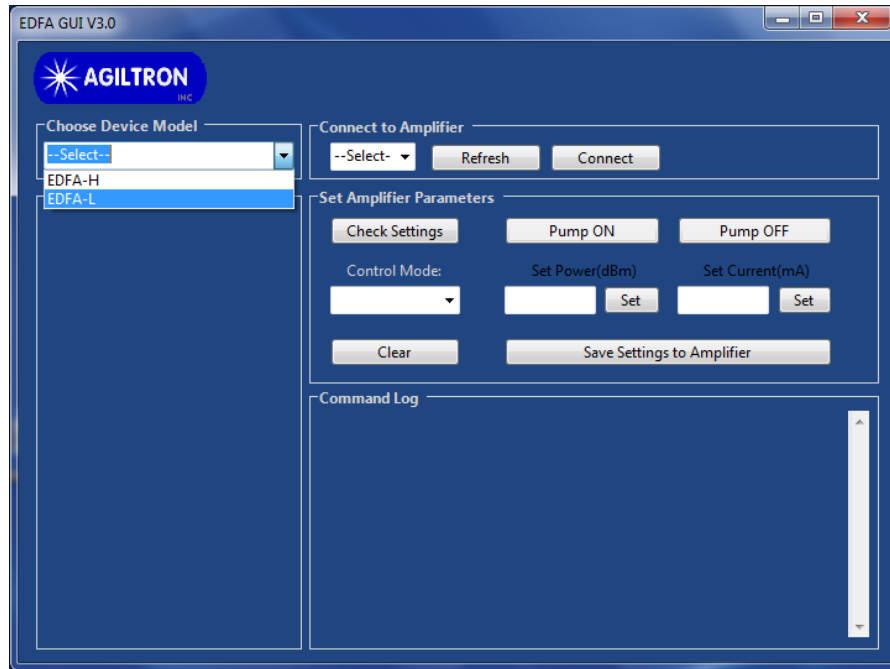

Figure 4 Remote control software: Model selection

7) Port Selection:

Select the serial port, to which the EDFA is connected, from the 'Port List', and click 'Connect'. If the desired port doesn't show up click 'Refresh' button and try again.

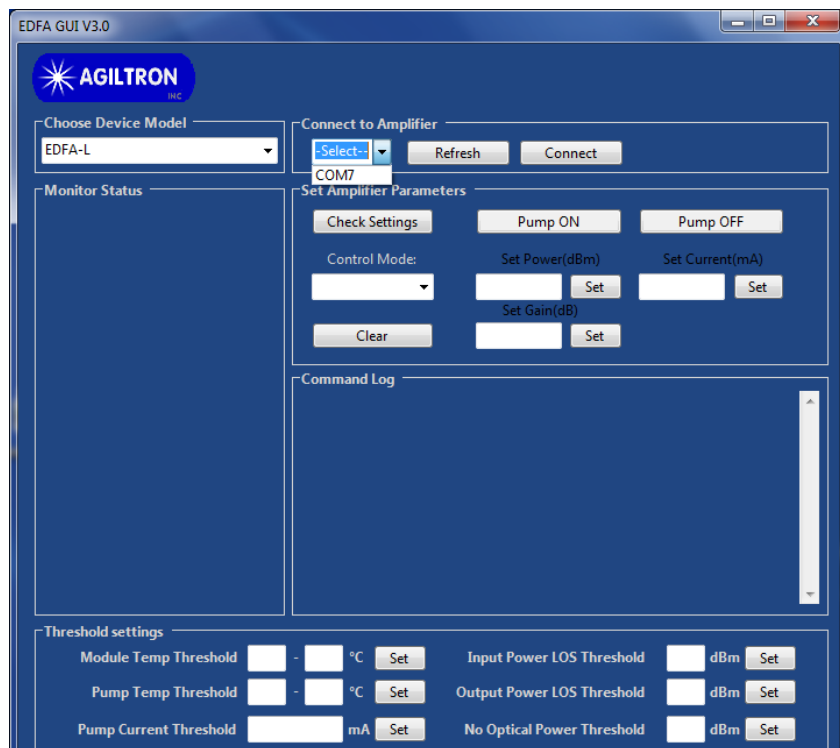

Figure 5 Remote control software: Port selection



Figure 6 Remote control software: connected successfully.

- 8) Once EDFA has been connected successfully the status of the EDFA will be displayed in Monitor Status window. The status keeps updating at an interval of 1 second.
- 9) Check Setting
Click to get the settings from the EDFA.
- 10) Pump ON/OFF
Click to turn on/off the EDFA pump laser, thus to turn on/off its output.



Figure 7 Remote control software: control mode selection

11) Control Mode Selection

Click 'Control Mode' button to get the current mode setting of EDFA.

- Power Control: constant power control mode
- Current mode: constant current control mode
- Gain Control: constant gain control mode, adjustable range is ± 3 dB

Select the desired mode and input setting value into the corresponding 'Set Power(dBm)', 'Set Current(mA)', or 'Set Gain (dB)' box, then click 'Set' button.

12) Save Settings

When 'Set' button is clicked, current settings will be saved to EDFA.

13) Emission ON/OFF

Click 'Pump ON' or 'Pump OFF' button to turn on/off the output of EDFA.