

# MEMS 1xN Fiber Optical Switch 1280-1650nm



N up to 256 ports, Crosstalk up to 70dB, Bidirectional, USB, RS232, I2C, TTL, UART

DATASHEET

[Return to the Webpage](#)



The MEMS 1xN Fiber Optical Switch employs a gold-coated reflecting silicon mirror to direct light from the input fiber to the selected output fiber with minimal path length difference between states. Its design uses bending single-crystal arms that do not fatigue or wear out, ensuring exceptional reliability and long operational life. The electrostatic actuator consumes little energy. The switch supports bidirectional operation and is available in single-mode, polarization-maintaining, and multimode fiber types. For Nx1 use, the total combined input power must remain within the specified maximum rating. Configurations include bare device, standalone module with TTL driver, or a plug-and-play PCB-mounted module featuring USB or RS-232 interfaces, GUI control software, a 5 VDC wall-pluggable supply, and computer interface cable. A vibration-insensitive version is available for deployment in airframes and vehicle environments. The MSWH is widely used in production testing, telecommunications, data centers, and laboratory applications.

## Applications

- Network
- Data Storage
- Sensor System
- Instrument

## Features

- Up to 380 Channels
- Crosstalk up to 70dB
- 780 to 2100nm
- SM, PM
- Compact
- Low Cost
- Bidirectional
- High Reliability

## Specifications

Parameter	Min	Typical	Max	Unit	
Wavelength	1280		1650	nm	
Wavelength Range		± 30		nm	
Insertion Loss [1]	<32 Channel	0.4	0.7	0.9	dB
	>32 Channel	1	1.3	1.6	
Cross Talk [2]	SM	55	60	70	dB
	MM	30	45	50	
Return Loss [3]	SM	50	50	55	-dB
	MM	30	30	35	
Repeatability	0.03		0.05	dB	
Polarization Dependent Loss (SM)		0.05	0.1	dB	
Polarization Extinction Ratio (PM)	18	23	29	dB	
Wavelength Dependent Loss [2]			0.3	dB	
Temperature Dependent Loss			0.2	dB	
Switching Time		5	10	ms	
Actuation		No-latching			
Optical Power Handling			500	mW	
Life Time	10 <sup>10</sup>			cycle	
Operating Temperature	-5		70	°C	
Storage Temperature	-40		80	°C	
Power Supply	0		5	VDC	
Operation Current			500	mA	
Digital Logic High	3.3		5	VDC	
Power Consumption			100	mW	

### Notes:

[1]: measured at 1550nm SM without connectors @CWL ±30nm, 23°C: Each connector adds 0.3dB.

[2]: @CWL ±30nm, 23°C

[3]: measured without connectors. With FC/ACP single mode fiber RL~60dB, and multimode fiber <40dB

**Note:** The specifications provided are for general applications with a cost-effective approach. If you need to narrow or expand the tolerance, coverage, limit, or qualifications, please [click this link](#):



**Legal notices:** All product information is believed to be accurate and is subject to change without notice. Information contained herein shall legally bind Agiltron only if it is specifically incorporated into the terms and conditions of a sales agreement. Some specific combinations of options may not be available. The user assumes all risks and liability whatsoever in connection with the use of a product or its application.

Rev 03/10/26

+1 781-935-1200

sales@agiltron.com

www.agiltron.com

# MEMS 1xN Fiber Optical Switch 1280-1650nm



N up to 256 ports, Crosstalk up to 70dB, Bidirectional, USB, RS232, I2C, TTL, UART

## DATASHEET

Typical Insertion Loss vs Wavelength (1240-1630nm, the large noise at end is due to low power)

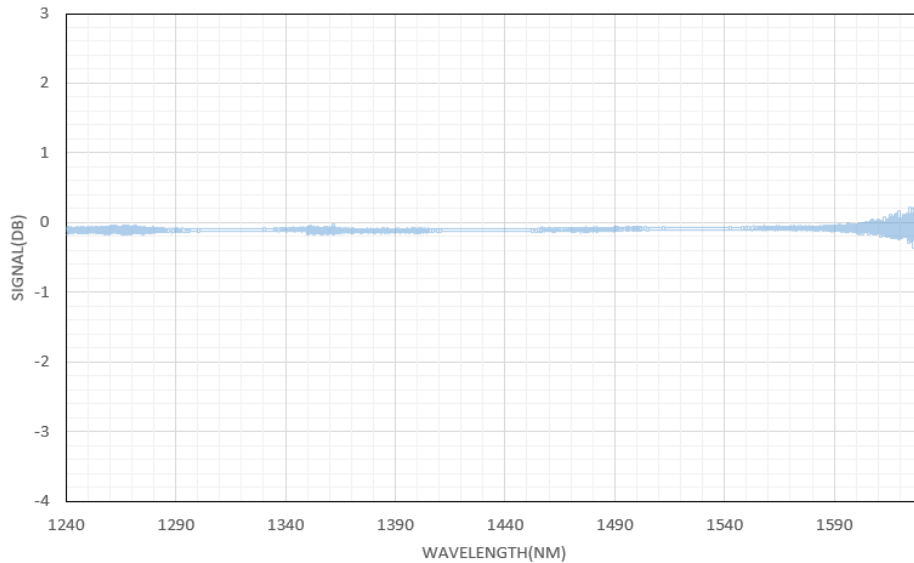

The oscillations at the long wavelength end is due to low light SLED source intensity

# MEMS 1xN Fiber Optical Switch 1280-1650nm



N up to 256 ports, Crosstalk up to 70dB, Bidirectional, USB, RS232, I2C, TTL, UART

## DATASHEET

### Optical Path Diagram

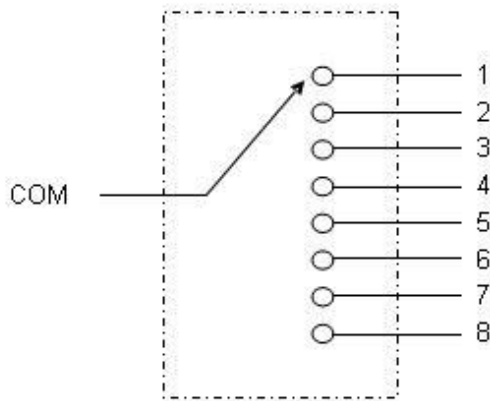

■ 1x8

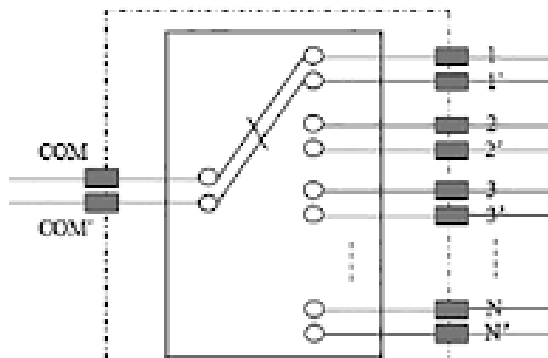

■ Duplex 1xN

### Three Package Formats



■ Bare Device N Type(with calibration table)



■ Mounted on Mini TTL PCB - O Type



■ Mounted on USB/RS232/TTL PCB with Power Supply

# MEMS 1xN Fiber Optical Switch 1280-1650nm



N up to 256 ports, Crosstalk up to 70dB, Bidirectional, USB, RS232, I2C, TTL, UART

## DATASHEET

### Ordering Information (Part Number)

Prefix	Configuration	Wavelength <sup>[1]</sup>	Package/Driver <sup>[2]</sup>	Fiber Type	Fiber Cover	Fiber Length	Connector <sup>[3][4]</sup>	On/Off	Vibration	PER	Enclosure
MSWH-	1x4 = AA4	1280-1650nm =1	USB/TTL = 1	SM28 = 1	Bare fiber = 1	0.25m = 1	None = 1	Regular = 1	Standard = 1	None = N	None = 1
	1x6 = AA6	1550nm = 5	RS232/TTL = 2	50/125 = 2	0.9mm tube =3	0.5m = 2	FC/PC = 2	SM/PM>62dB =2	Insensitive =2	Regular =1	Benchtop = B
	1x8 = AA8	1310nm = 3	TTL (O type) = O	Hi1060 = 3	Special = 0	1.0m = 3	FC/APC = 3	MM>50dB = 3	Special = 0		Rack = R
	1x12 = A12	1310/1550nm =B	TTL (A type) = T	PM1550 = 4		Special = 0	SC/PC = 4				
	...	850nm = 8	UART/TTL = A	62.5/125 = 5			SC/APC = 5				
	1x64 = A64	760-1360nm = C	Bare (B type) = B	105/125 = A			SC/UPC = 5				
	...	1060nm = 6	Special = 0	SM600 = 6			ST/PC = 6				
	1x256 = 256	980nm = 9		SM1950 = 9			LC/PC = 7				
	...	780nm = 7		SM800 = 8			MTP = 9				
	1x380 = 380	1950nm = D		780HP = 7			LC/APC = A				
		895nm = E		PM850 = E			LC/UPC = U				
	Dual1x4 = DA4	Special = 0		PM980 = F			MPO = Y				
	Dual1x8 = DA8			PM1310 = D			Special = 0				
	Dual1x12 =D12			Special = 0							
	...										
Dual1x64 =D64											

- [1]. Selections of **5**, **3**, **B** are the same device as **1**, Selection **8** and **C** are the same device, but test at different wavelength with extra cost.
- [2]. Selections **1** and **2** are mounted on plug-play drivers: Driver Part Number: SWDR-S1XN2D5VSUSB/TTL. Driver Part Number: SWDR-S1XN2D5VSR5232/TTL  
 Selection **T** is a standard module package mount on PCB with specific pin definition. **C** and **A** are special module PCB  
 Selection **N** is bare device comes with a look-up position voltage table. Cost is higher than **T**
- [3]. Regular fiber connector has PER ~22dB. Connector with PER >27 dB is available using special process
- [4]. The connector cannot be installed directly onto bare fiber, as it is prone to damage during shipping. However, the connector can be assembled on bare fiber if a 3 cm protective loose tube is added for reinforcement. The customer can remove this protective tube after testing. The optical power handling of a standard connector is less than 0.5 W for SM28 fiber and decreases further with smaller core fibers.

**Note:**

- PM1550** fiber works well for **1310nm**

## Application Notes

### Fiber Core Alignment

Note that the minimum attenuation for these devices depends on excellent core-to-core alignment when the connectors are mated. This is crucial for shorter wavelengths with smaller fiber core diameters that can increase the loss of many decibels above the specification if they are not perfectly aligned. Different vendors' connectors may not mate well with each other, especially for angled APC.

### Fiber Cleanliness

Fibers with smaller core diameters (<5 μm) must be kept extremely clean, contamination at fiber-fiber interfaces, combined with the high optical power density, can lead to significant optical damage. This type of damage usually requires re-polishing or replacement of the connector.

### Maximum Optical Input Power

Due to their small fiber core diameters for short wavelength and high photon energies, the damage thresholds for device is substantially reduced than the common 1550nm fiber. To avoid damage to the exposed fiber end faces and internal components, the optical input power should never exceed 20 mW for wavelengths shorter 650nm. We produce a special version to increase the how handling by expanding the core side at the fiber ends.

# MEMS 1xN Fiber Optical Switch 1280-1650nm



N up to 256 ports, Crosstalk up to 70dB, Bidirectional, USB, RS232, I2C, TTL, UART

## DATASHEET

### Dimension (mm) Bare Components -B Type Package

1xN, N<16

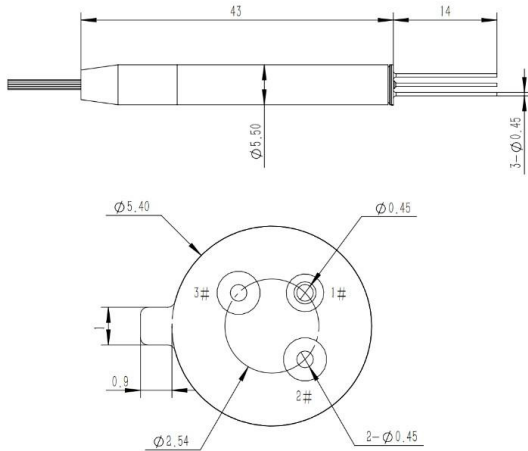

Pin number	Description
1	GND
2	Axis Y
3	Axis X

1xN, 16<N<32

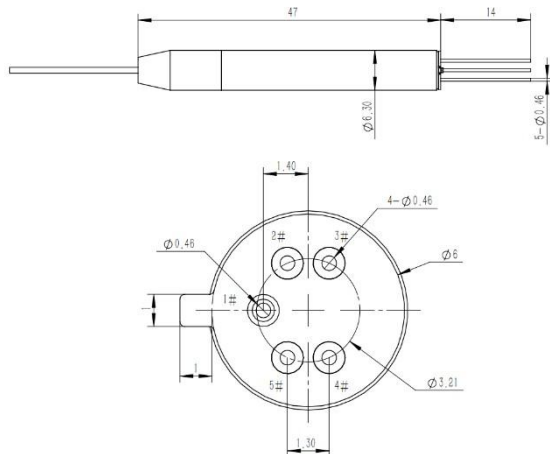

Pin number	Description
1	GND
2	Axis X+
3	Axis Y-
4	Axis X-
5	Axis Y+

1xN, 32<N<64

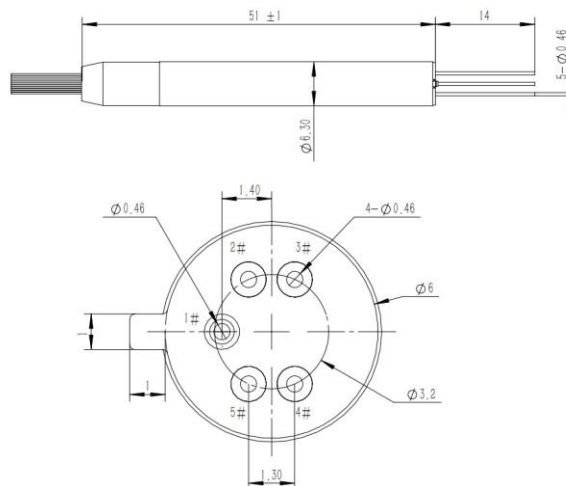

Pin number	Description
1	GND
2	Axis X+
3	Axis Y-
4	Axis X-
5	Axis Y+

# MEMS 1xN Fiber Optical Switch 1280-1650nm



N up to 256 ports, Crosstalk up to 70dB, Bidirectional, USB, RS232, I2C, TTL, UART

## DATASHEET

### Dimension (mm) Mounted on Mini PCB Type T Package

#### Module Type A (1xN, 2 < N ≤ 16)

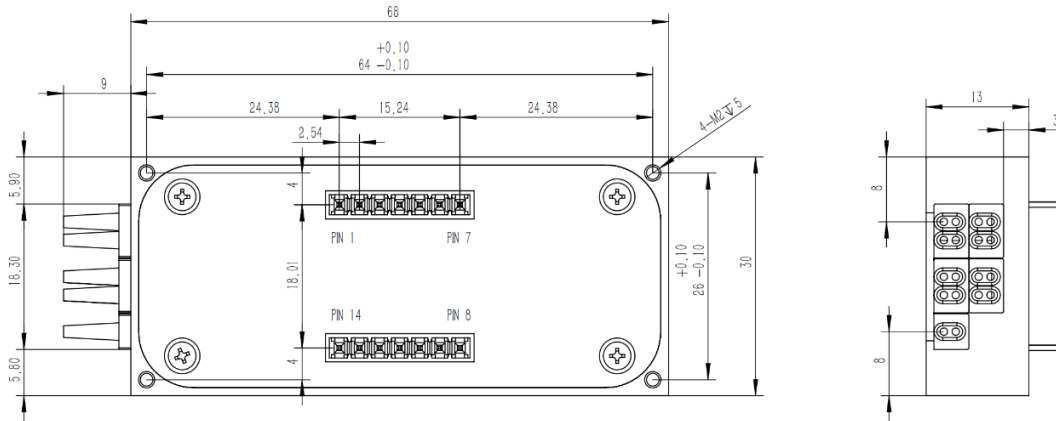

#### Module Type A (1xN, 16 < N ≤ 32)

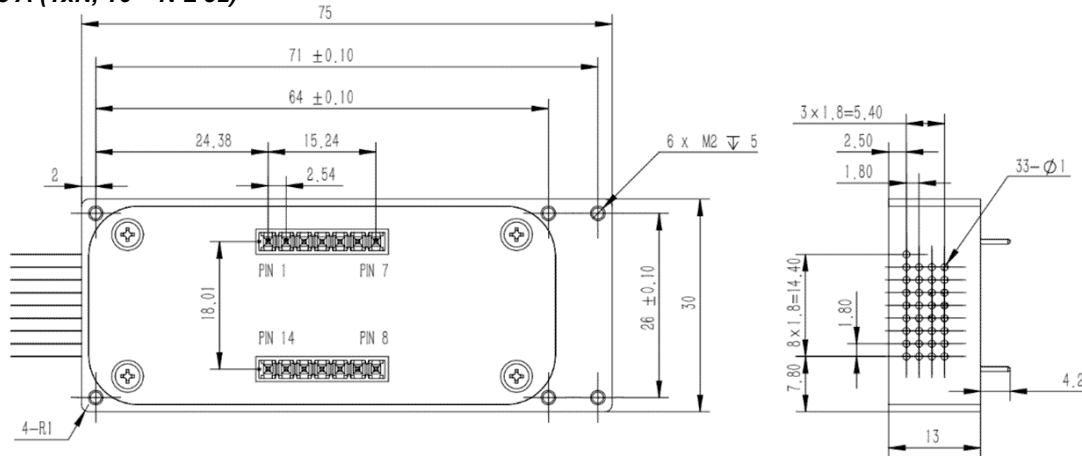

#### Module Type A (1xN, 48 ≤ N ≤ 64)

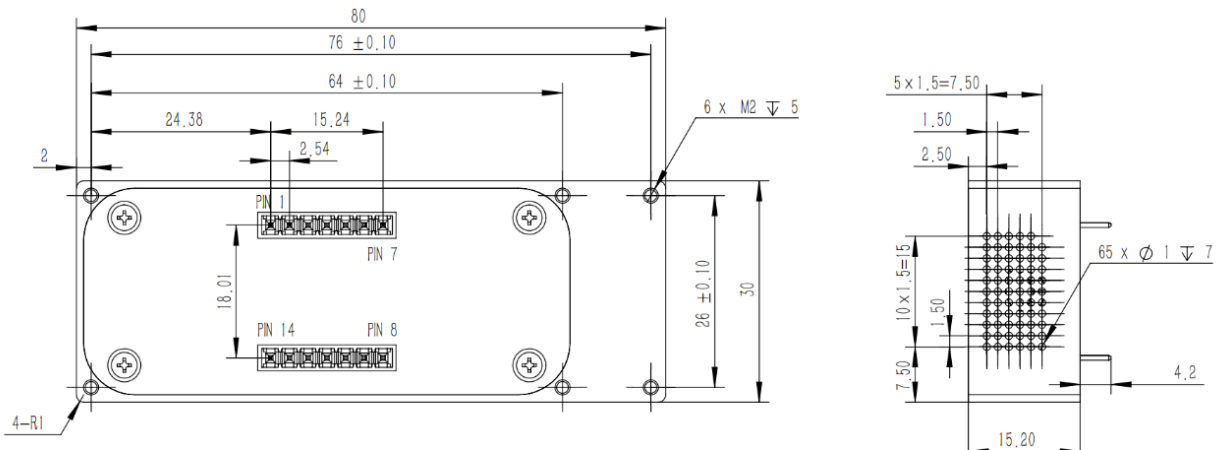

# MEMS 1xN Fiber Optical Switch 1280-1650nm



N up to 256 ports, Crosstalk up to 70dB, Bidirectional, USB, RS232, I2C, TTL, UART

## DATASHEET

### Dimension (mm) Mounted on Mini PCB Type O Package

#### Module Type 0 (1xN, 2 < N ≤ 8)

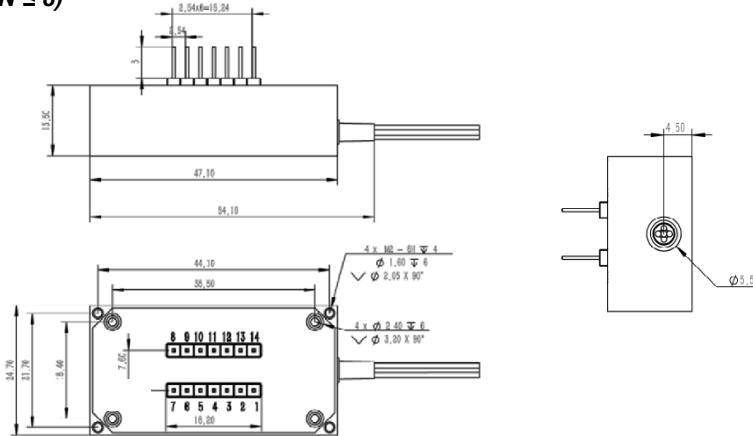

#### Module Type 0 (1xN, 8 < N ≤ 12)

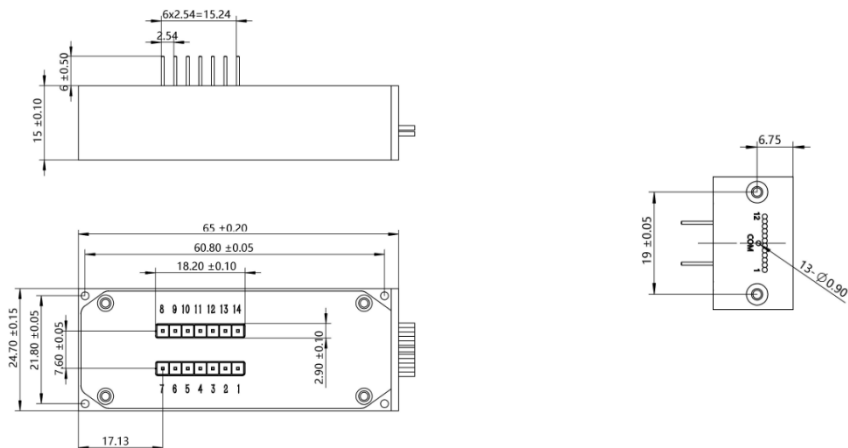

#### Module Type 0 (1xN, 12 ≤ N ≤ 32)

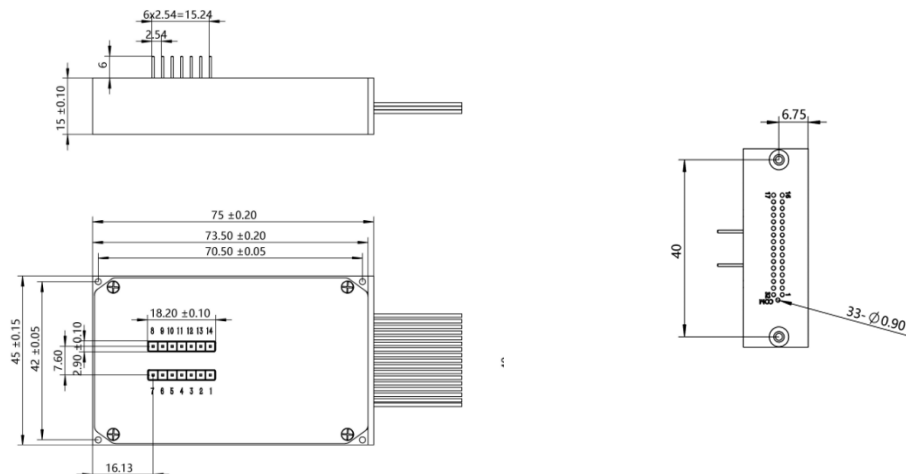

# MEMS 1xN Fiber Optical Switch 1280-1650nm



N up to 256 ports, Crosstalk up to 70dB, Bidirectional, USB, RS232, I2C, TTL, UART

## DATASHEET

### PIN Definition For O Type Package

Pin	Type	Description	Input/Output	Remark
1	D0	Parallel Data Interface 0	Input	TTL (H level default)
2	D3	Parallel Data Interface 3	Input	TTL (H level default)
3	D4	Parallel Data Interface 4	Input	TTL( H level default)
4	VIN	Power Input	Input	DC 5V~12V
5	GND	GND	Input	
6	D5	Parallel Data Interface 5	Input	TTL (H level default)
7	D2	Parallel Data Interface 2	Input	TTL (H level default)
8	TX	Serial port send	Output	TTL
9	RX	Serial port receive	Input	TTL
10	D1	Parallel Data Interface 1	Input	TTL
11	BUSY	Busy signal, high level indicates busy	Output	TTL
12	ALARM	Alarm signal, high level indicates high temperature or Initial Abnormal	Output	TTL
13	STROBE	Signal of parallel port selection, falling edge is effective	Input	TTL (H level default)
14	RESET	Hardware reset, low level effective	Input	TTL

### Parallel Digital I/O Control For O Type Package

TTL control can only be used for optical switches with up to 32 channels with 5 TTL control pins (D0~ D4).

Channel	D4	D3	D2	D1	D0
CH1	0	0	0	0	0
CH2	0	0	0	0	1
CH3	0	0	0	1	0
CH4	0	0	0	1	1
...	...	...	...	...	...
CH8	0	0	1	1	1
CH16	0	1	1	1	1
CH32	1	1	1	1	1

**Notes:**

When optical switch is 1x8, D3 and D4 is not used. Similarly for other 1xN.

### I2C Bus

I <sup>2</sup> C bus specifications	Minimum	Typical	Maximum
I <sup>2</sup> C Clock frequency	10kHz	100kHz	100kHz
Capacitive loading			400pF

The list shows the commands, which are sent to module, and the response from the module.

**I2C address:**

1	1	1	0	0	0	0	R/W
---	---	---	---	---	---	---	-----

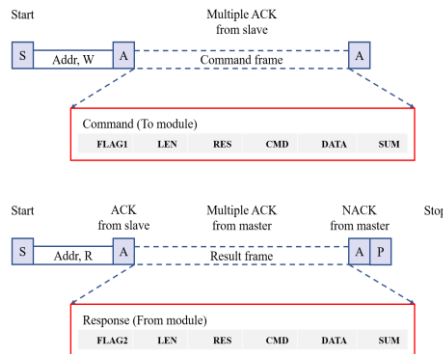

# MEMS 1xN Fiber Optical Switch 1280-1650nm



N up to 256 ports, Crosstalk up to 70dB, Bidirectional, USB, RS232, I2C, TTL, UART

## DATASHEET

### Communication Protocol For O Type Package

Item	Bytes	Type	Note
Vendor Code	10	ASCII	
Reserved	10	ASCII	Information about the channel and the type
Hardware Version	2	Hex	X.Y (X—byte0 Y—byte1)
Firmware Version	2	Hex	X.Y (X—byte0 Y—byte1)
Production Date	4	Hex	YYYY—MM—DD YYYY—byte0 byte1 MM—byte2 DD—byte3
Serial Number	8	ASCII	

### Reset Module

Command	FLAG1	LEN	RES	CMD	DATA	SUM
	0xEFEF	0x03	0xFF	0x03		SUM
Response	FLAG2	LEN	RES	RESP	DATA	SUM
	0xEDFA	0x03	0xFF	0x03		SUM

# MEMS 1xN Fiber Optical Switch 1280-1650nm



N up to 256 ports, Crosstalk up to 70dB, Bidirectional, USB, RS232, I2C, TTL, UART

## DATASHEET

### Electronic PINs Definition For A Type Package

#### UART /TTL Definition (Default)

Pin	Name	Description	Input / Output	Level
1	NC		No connect	
2	VCC	+(5.0±5%) V Power Supply Max 150mA	Power supply	
3	STROBE	Falling edge active	Input	LVTTTL
4	GND	Power supply ground		
5	D0		Input	LVTTTL
6	TXD	UART serial data output	Output	LVTTTL
7	RXD	UART serial data output	Input	LVTTTL
8	D4		Input	LVTTTL
9	D2		Input	LVTTTL
10	DONE	Switch done, active low	Output	LVTTTL
11	Case GND	Case ground		
12	D1		Input	LVTTTL
13	D3		Input	LVTTTL
14	RESET	Reset, low active, the pulse width needs 4ms	Input	LVTTTL

#### IIC Definition (Optional)

Pin	Name	Description	Input / Output	Level
1	NC		No connect	
2	VCC	+(5.0±5%) V Power Supply Max 150mA	Power supply	
3	I/O	Reserved		LVTTTL
4	GND	Power supply ground		
5	I/O	Reserved		LVTTTL
6	I2C Data <sup>[1]</sup>	I2C interface Data	I/O	LVTTTL
7	I2C Clock <sup>[1]</sup>	I2C interface Clock	I/O	LVTTTL
8	I/O	Reserved		LVTTTL
9	I/O	Reserved		LVTTTL
10	I/O	Reserved		LVTTTL
11	Case GND	Case ground		
12	I/O	Reserved		LVTTTL
13	I/O	Reserved		LVTTTL
14	RESET	Reset, low active, the pulse width needs 4ms	Input	LVTTTL

#### Notes:

- [1]. Please pull up 4.75k resistor to 3.3V in the module;
- [2]. Please pull up 4.75k resistor to 3.3V on mother board;
- [3]. Please pull up 4.75k resistor to 3.3V in the module. A negative pulse  $\geq 1$ ms.

### UART Control Setting

Baud Rate: 115200  
Start Bits: 1  
Data Bits: 8  
Parity: None  
Stop Bits: 1  
Flow Control: None

# MEMS 1xN Fiber Optical Switch 1280-1650nm



N up to 256 ports, Crosstalk up to 70dB, Bidirectional, USB, RS232, I2C, TTL, UART

## DATASHEET

### Mechanical Dimension (mm) -- Benchtop

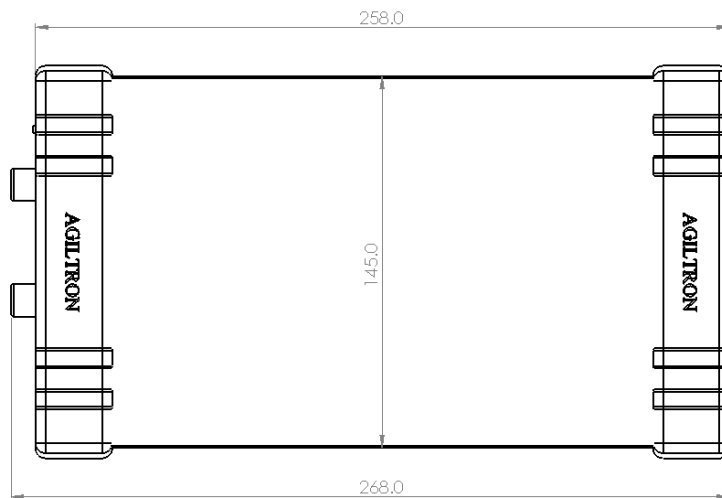
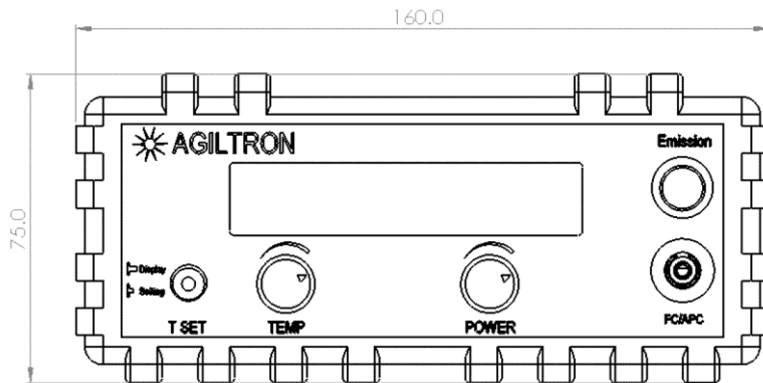

# MEMS 1xN Fiber Optical Switch 1280-1650nm



N up to 256 ports, Crosstalk up to 70dB, Bidirectional, USB, RS232, I2C, TTL, UART

## DATASHEET

### Plug-Play PCB Driver Dimension (mm) 1x64

1xN, 2 < N ≤ 64 on USB/ TTL PCB

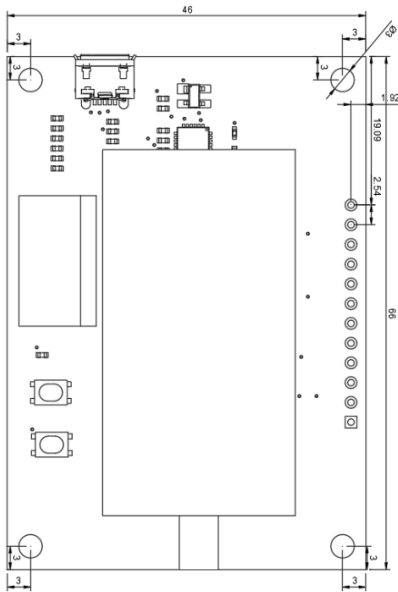

1xN, 2 < N ≤ 64 on RS232/TTL PCB

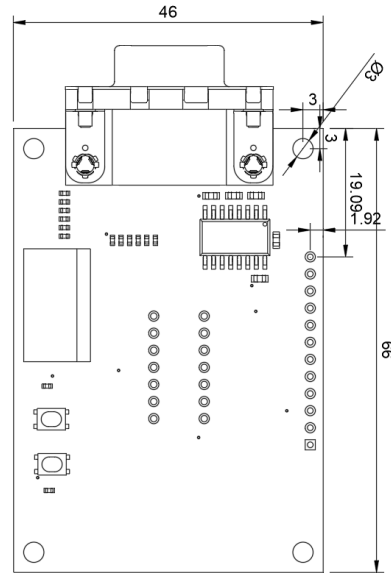

TTL Control Pin on PCB- 2.54mm Pitch, 0.64mm Square Header

### Interface Definition (1x64)

Name	Direction	Description
5V	Power	The driver board can also be powered up via these two holes.
GND	Ground	
D0-D5	Input	6 Flip Switches
STR	Input	STROBE, Send a pulse to set the switch channel
RST	Input	RESET, Send a pulse to reset switch status
BUSY	Output	Logic HIGH when the device is busy
ALARM	Output	Logic HIGH indicates when booting/ high temperature

CH	D5	D4	D3	D2	D1	D0
1	0	0	0	0	0	0
2	0	0	0	0	0	1
3	0	0	0	0	1	0
.						
64	1	1	1	1	1	1

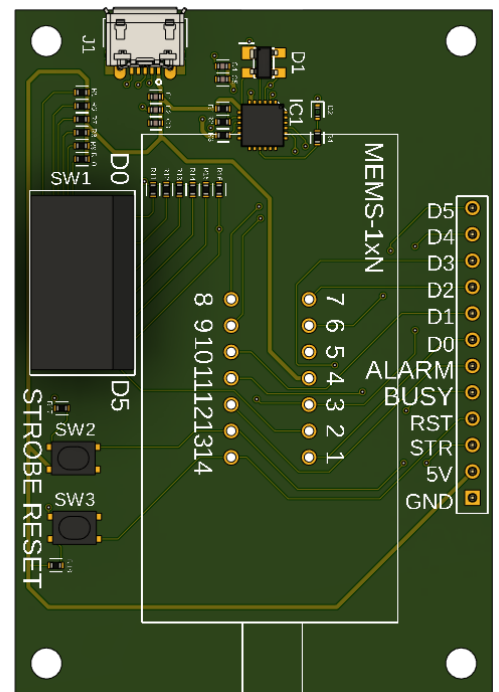

# MEMS 1xN Fiber Optical Switch 1280-1650nm



N up to 256 ports, Crosstalk up to 70dB, Bidirectional, USB, RS232, I2C, TTL, UART

DATASHEET

## DC Power Supply Power Cord

### DC Power Cable, 5.5mm/2.1mm Female To Open, 2-Foot

The DC power cable with a 5.5mm/2.1mm female to open connector configuration. Our 2-foot long DC cable assembly is used in numerous small devices from household appliances and devices to network extenders and switches. This DC power cable is suitable for device manufacturing, network wiring, industry, telecom, office installation, DC power adapters, AC power cords, switches and extenders, USB cables, and power to small device applications. Our 2-foot power cables have a center-positive connector.



#### NOTES:

1. MATERIAL: CABLE: 22 AWG, 2 CONDUCTORS, PVC JACKET OD: .071 X .142 ±.006 [1.8 X 3.6 ±0.15]
2. MARKING: AWM 2468 80°C 300V 22AWG\*2C VW-1 P1 PLUG: DC  $\phi$  5.5 X 2.1 mm FEMALE, NICKEL PLATED
3. REGULATORY COMPLIANCE: EU RoHS DIRECTIVE (MOST RECENT RELEASED VERSION).

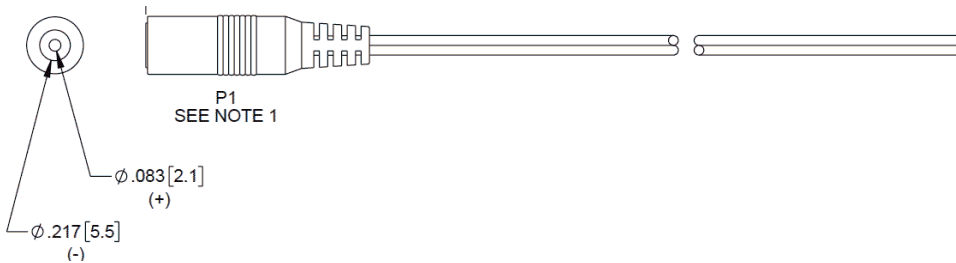

## Driver Description

The MSWH MEMS 1xN Driver (Up to 164 ports) has three control modes: (1) USB/TTL (Virtual COM) with a user-friendly GUI Windows™ program supporting UART commands. The unit has a mini USB connector with a USB-to-MicroUSB cable. It can be powered by a 5V USB cable and USB power supply or via onboard 5V-GND holes. (2) RS232/TTL with a user-friendly GUI Windows™ program supporting UART commands. The unit has an RS232 connector. As shown below the switches are mounted on these driver PCBs and tested prior to shipping. This makes integration or performance evaluation easy. (3) The switches can also be mounted directly onto the customer PCB with 14 pins, following detailed instructions. This approach requires customers to have circuit design experience.

## Manual Onboard Operation Instruction

#### • Power the Board

Power up the unit via 5V USB power supply which is included in the shipping box

#### • Onboard Push Button Switch Control

Tun on the DIP-6 switch for manual control. After setting the DIP-6 switch, press the STROBE (Switch2) button to change the channel of MEMS 1xN switch. Press the Reset (Switch3) button to go back to the original no light output position.

## Manual Remote Operation Instruction

#### • Power the Board

Power up the unit via 5V USB power supply which is included in the shipping box

#### • Making Remote Switch Control Connection

For STROBE, y connect a momentary switch between STR pin and 5V pin.

For RESET, a momentary switch between RST and GND pin.

# MEMS 1xN Fiber Optical Switch 1280-1650nm



N up to 256 ports, Crosstalk up to 70dB, Bidirectional, USB, RS232, I2C, TTL, UART

## DATASHEET

### Command List (we provide service to write LabVIEW and python for customer integration )

- **Command in Serial**

The serial communication should be set in **115200 baud rate, none parity, 8 data bits, 1 stop bits.**

Command in **ASCII**:

1. Check PN of device:

CMD: \*PN<cr>

RTN: <cr><lf>AB.CD.EFGH<cr><lf>

2. Check SN of device:

CMD: \*SN<cr>

RTN: <cr><lf>ABCDEFGHIJ<cr><lf>

3. Set Channel:

CMD: \*SWABC<cr>

RTN: <cr><lf>CHAN:ABC<cr><lf>

Example: \*SW001<cr> RTN: <cr><lf>CHAN:001<cr><lf>

Note: <cr> is 0x0C in HEX, \n in ASCII

## GUI User Guide

- **Install the Program**

Click on setup.exe for the automatic installation, which should be provided with the product.

- **Run the Program**

Run the "Switch Operation Program.exe" and the program will open the configuration window. Select the correct Switch Group and select the specific Switch Type. Then click the "Connect" button and the program will establish the connection between PC and board.

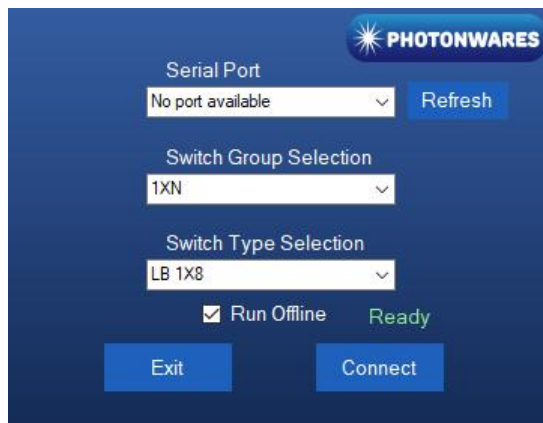

# MEMS 1xN Fiber Optical Switch 1280-1650nm



N up to 256 ports, Crosstalk up to 70dB, Bidirectional, USB, RS232, I2C, TTL, UART

## DATASHEET

### Operation Instruction

1. **Add Step:** Click the “Add Step” button in the menu strip or click the “+(ADD)” button to add a step to the Programmable Running Sheet.

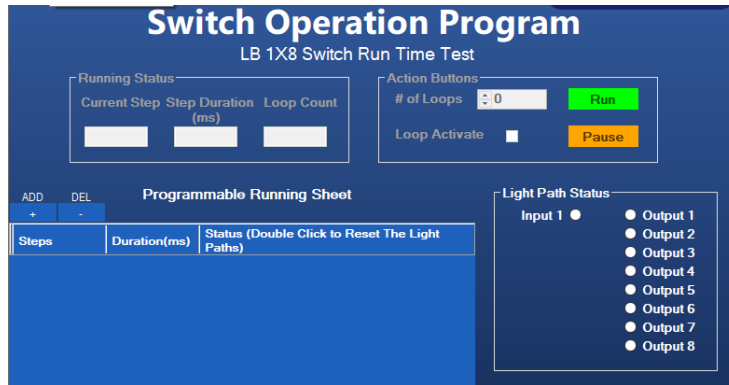

2. **Input Duration:** Click the “Duration” button in the Programmable Running Sheet. Input time duration in ms.



3. **Input Lightpath :** Click the “Status” button in the Programmable Running Sheet. Select and input lightpath.

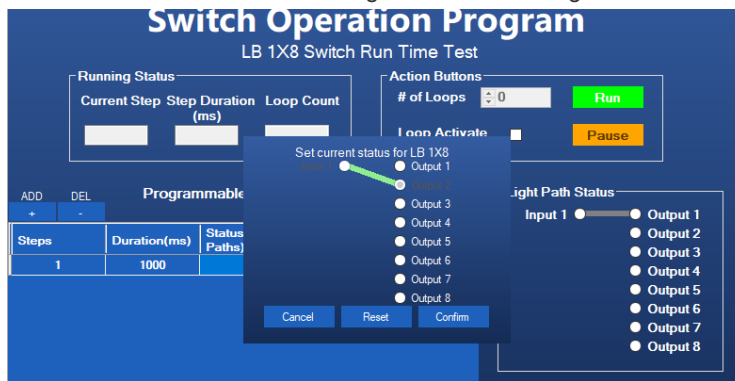

4. **Add Another Step:** The above process can be repeated to create a sequential running receipt.

5. **Delete step:** Click the “Delete Step” button in the menu strip or click the “-(DEL)” button would both delete a step in the Programmable Running Sheet.

6. **Edit step:** There are two things that you can modify for one step. One is the light path, and the other is the duration for each step. Double click the cell that you want to modify, and the program will allow you to modify the setting.

7. **Running:** The entered receipt can be running repeatedly in loops. Enter loop number in the “Action Button”. Click “Run” to start the switching receipt. The process can be paused by clicking “Pause” or stopped by clicking “Run”

7. **Display:** All aspects of the switch action in the Programmable Running Sheet will be displayed by boxes, color, and visual lines.