

2 μm High Power Fiber Isolator (50W CW)

(patents pending)



DATASHEET

BUY NOW



This 2 μm passive device transmits high power light from input fiber into output fiber while blocking the unwanted light from back reflection and scattering. Agiltron's proprietary magnetic-optics technology and advanced micro-optic technique enable industrial leading performance in power handling, low loss, reliability, and cost effective. Agiltron currently provides a full range of polarization-independent, polarization maintaining, and custom design versions with a broad wavelength coverage and various output beam diameters. We have experience to incorporate special fibers.

Features

- High Power Handling
- High Isolation
- High Reliability
- Low IL, PDL & TDL
- Cost Effective

Applications

- Laser Pump Source
- Optical Fiber Amplifier
- Laser Manufacturing
- Laser Marking

Specifications

Parameter	Min	Typical	Max	Unit
Operation Wavelength	1940	2000	2050	nm
Insertion Loss ^[1]		1.2		dB
Isolation		25		dB
Polarization Dependent Loss		0.2		dB
Extinction Ratio ^[2]		20		
Polarization Mode Dispersion		0.1	0.2	ps
Return Loss		50		dB
Optical Power Handling ^[3]			50	W
Back Reflect Power			15	W
Fiber Type	See Order Information			
Operating temperature	0 to 60			°C
Storage Humidity	5% to 95% (No Condensation)			

Notes:

- [1]. Measured without connectors
- [2]. For PM version only
- [3]. Continuous operation, for pulse operation call

Note: For a polarized input light version, the isolation is optimized to block the light reflection of the same polarization. Although lights of other polarizations may also be blocked, the extinction may be poor. PM isolators can be specially made to block backward propagating lights of all polarizations. PM isolators can also be made with a light polarizing function.

Legal notices: All product information is believed to be accurate and is subject to change without notice. Information contained herein shall legally bind Agiltron only if it is specifically incorporated into the terms and conditions of a sales agreement. Some specific combinations of options may not be available. The user assumes all risks and liability whatsoever in connection with the use of a product or its application.

Rev 04/02/24

2 μm High Power Fiber Isolator (50W CW)

(patents pending)



DATASHEET

Mechanical Footprint Dimensions (mm)

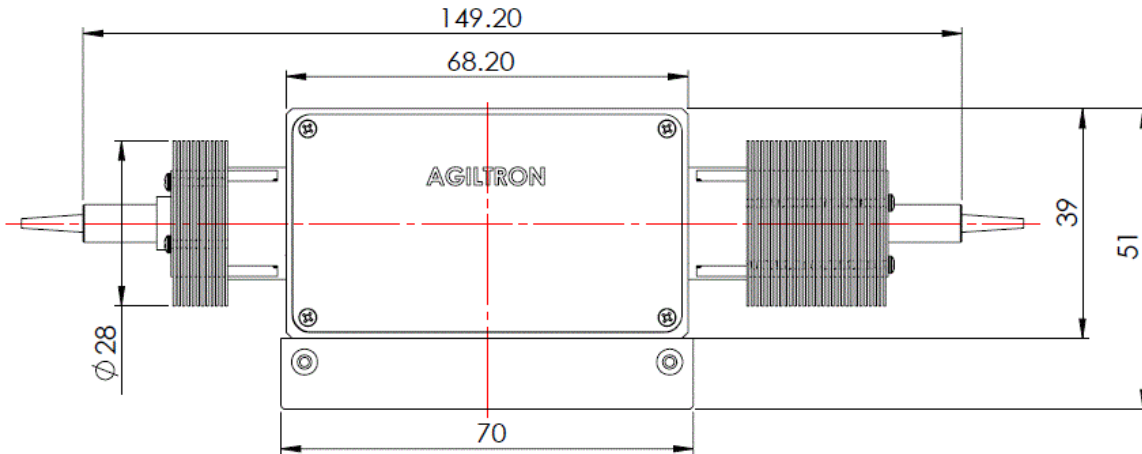

*Product dimensions may change without notice. This is sometimes required for non-standard specifications.

Ordering Information (Part Number)

Prefix	Type	Wavelength	Power Handling	Package	Fiber Type	Fiber Cover	Fiber Length	Connector
FSOI-	Regular = 11 PM = 12 Special = 00	2000nm = 1 Special = 0	50W = 8	Standard = 1 Special = 0	SMF28 = 2 PM1550 = 5 Special = 0	Bare fiber = 1 900um loose tube = 3 Armor cable = 5 Special = 0	0.25m = 1 0.5m = 2 1.0 m = 3 Special = 0	None = 1 FC/PC = 2 FC/APC = 3 SC/PC = 4 SC/APC = 5 ST/PC = 6 LC/PC = 7 LC/APC = A LC/UPC = U Special = 0

2 μm High Power Fiber Isolator (50W CW)

(patents pending)



DATASHEET

Application Notes

Fiber Core Alignment

Note that the minimum attenuation for these devices depends on excellent core-to-core alignment when the connectors are mated. This is crucial for shorter wavelengths with smaller fiber core diameters that can increase the loss of many decibels above the specification if they are not perfectly aligned. Different vendors' connectors may not mate well with each other, especially for angled APC.

Fiber Cleanliness

Fibers with smaller core diameters ($<5 \mu\text{m}$) must be kept extremely clean, contamination at fiber-fiber interfaces, combined with the high optical power density, can lead to significant optical damage. This type of damage usually requires re-polishing or replacement of the connector.

Maximum Optical Input Power

Due to their small fiber core diameters for short wavelength and high photon energies, the damage thresholds for device is substantially reduced than the common 1550nm fiber. To avoid damage to the exposed fiber end faces and internal components, the optical input power should never exceed 20 mW for wavelengths shorter 650nm. We produce a special version to increase the handling by expanding the core side at the fiber ends.