

Fiber Coupled 35 GHz Linear Photoreceiver

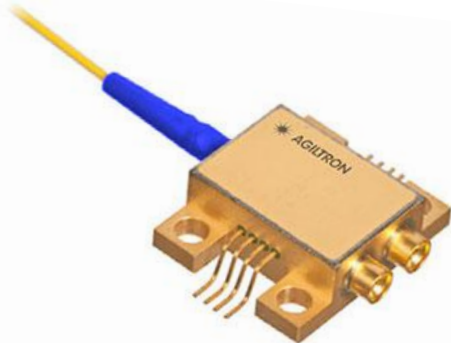

The FORX Linear Photoreceiver is designed for high-speed analog and digital applications, featuring a surface-coupled coplanar waveguide PIN photodiode and a linear transimpedance amplifier within a hermetically sealed 14-pin butterfly package. Its high conversion gain and low input-referred noise ensure exceptional linearity and precision.

For added convenience, Agiltron offers a driving PCB for easy integration and a metal box protective package to safeguard against ESD in laboratory environments, both come with a specially designed low noise power supply.

Due to their high sensitivity to electrostatic discharge, warranty coverage applies only to fully metal covered modules the benchtops, which include proper protection. Other versions of the lasers and photodetectors are not covered by any warranty. Please use them with great caution.

Features

- 35 GHz Bandwidth
- -11dBm Sensitivity
- Hermetically Sealed Package
- Linear TIA Integrated

Applications

- Low Noise Analog Heterodyne Detection
- Transponder and Line Card Designs
- Linear Receiver up to 30 GHz
- 30 GHz Analog RFoF Link

Specifications

Parameter	Min	Typical	Max	Unit
Wavelength Range	1200		1650	nm
Optical Input Power			+3	dBm
Bandwidth (-3 DB electrical @ max. gain)		29	35	GHz
Dark Current @ 30 °C, 3.3 V		5		nA
Sensitivity @ 1550 nm *	-11		-9	dBm
Optical Return Loss	-30		-27	dB
Polarization Dependent Loss		0.1		dB
PD Reverse Bias Voltage	3		4.5	V
Amplifier Supply Voltage	3.1	3.3	3.5	V
Electrical Return Loss (0.1 to 25 GHz)		< -15		dB
Impedance		50		Ω
Output Coupling	DC (external AC coupling required)			
Noise Equivalent Power (NEP) (@ 1 GHz)		17		pW/√Hz
Operating Temperature	-30		+75	°C
Storage Temperature	-50		+85	°C
Operating Humidity		85		%
Supply Current		90		mA
Power Consumption		300	350	mW
Package Type	8-pin butterfly min-DIL			
RF Connector	Dual GPPO			
ESD, Input and Output Pins	1000			V
ESD, All Other Pins	2000			V

* 10⁻¹² BER, PRBS 2³¹-1



Legal notices: All product information is believed to be accurate and is subject to change without notice. Information contained herein shall legally bind Agiltron only if it is specifically incorporated into the terms and conditions of a sales agreement. Some specific combinations of options may not be available. The user assumes all risks and liability whatsoever in connection with the use of a product or its application.

Rev 02/06/26

Fiber Coupled 35 GHz Linear Photoreceiver



DATASHEET

Dimensions (mm [inches])

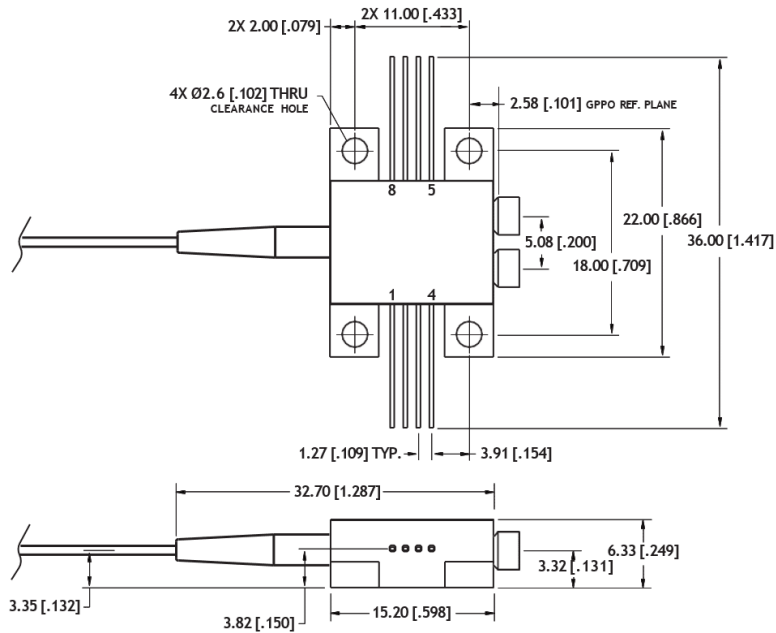

*Product dimensions may change without notice. This is sometimes required for non-standard specifications.

PIN	Description	PIN	Description
1	Vpd	5	NIC
2	GND	6	Vamp
3	NIC (No internal connection)	7	GND
4	NIC	8	Reserved (Rth)

Application Notes

Electrostatic discharge (ESD) will cause permanent damage to the product. Please avoid any ESD to the input pins or output connector. Use standard ESD protective equipment when handling this product.

Temperature and fiber restrictions are as follows: Lead soldering: 250°C for no more than 10 seconds Fiber feed-through tube:

- 120°C
- Fiber pull force: 4.9 N
- Fiber bending radius: 1 inch or less

Exceeding these conditions can cause permanent damage to the device.

Fiber Coupled 35 GHz Linear Photoreceiver



DATASHEET

Functional Diagram

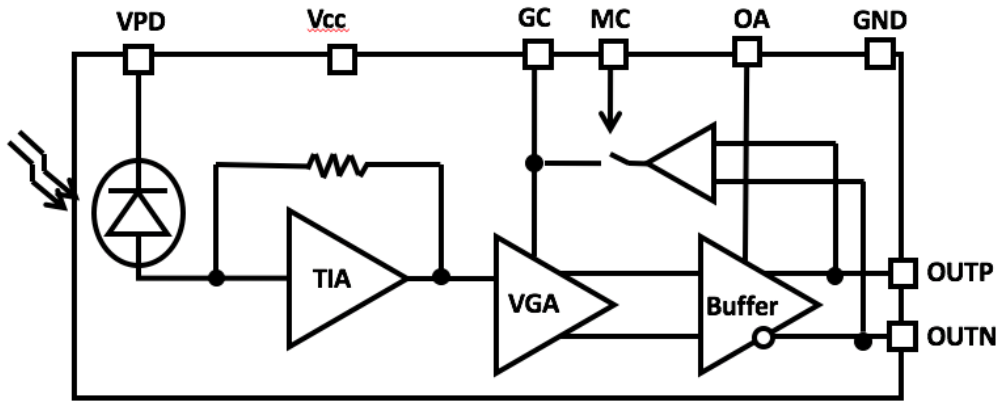

S21 Frequency Response

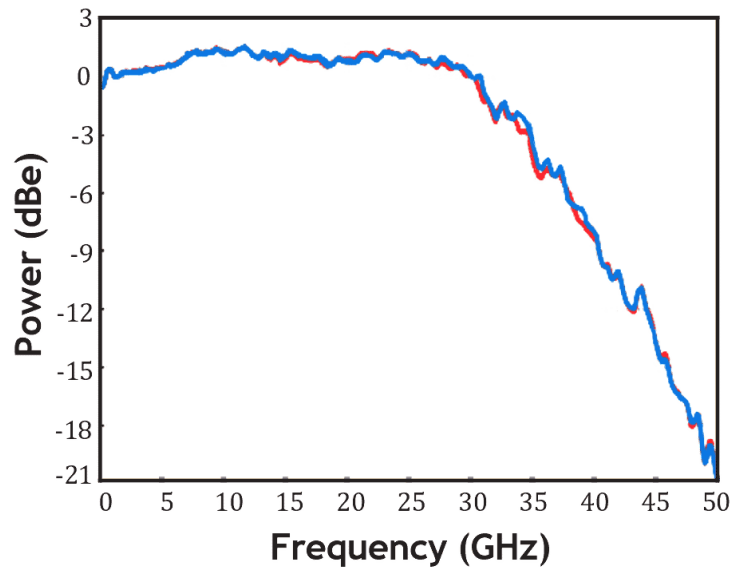

Fiber Coupled 35 GHz Linear Photoreceiver



DATASHEET

Ordering Information (Part Number)

	1	<input type="checkbox"/>	30	1	<input type="checkbox"/>	11	<input type="checkbox"/>
Prefix	Detector Type	Wavelength Range	Bandwidth	TEC	Module*	Configuration	Connector ^[1]
FORX-	PIN = 1 APD = 2	1300-1600nm = 1	30GHz = 30	Non = 1	Non = 1 Yes = 2	Standard = 11	FC/PC = 2 FC/APC = 3 Special = 0

[1]. The connector cannot be installed directly onto bare fiber, as it is prone to damage during shipping. However, the connector can be assembled on bare fiber if a 3 cm protective loose tube is added for reinforcement. The customer can remove this protective tube after testing. The optical power handling of a standard connector is less than 0.5 W for SM28 fiber and decreases further with smaller core fibers.

Fiber Coupled 35 GHz Linear Photoreceiver

DATASHEET

Laser Safety

This product meets the appropriate standard in Title 21 of the Code of Federal Regulations (CFR). FDA/CDRH Class 1M laser product. This device has been classified with the FDA/CDRH under accession number 0220191. All versions of this laser are Class 1M laser products, tested according to IEC 60825-1:2007 / EN 60825-1:2007. An additional warning for Class 1M laser products. For diverging beams, this warning shall state that viewing the laser output with certain optical instruments (for example eye loupes, magnifiers, and microscopes) within a distance of 100 mm may pose an eye hazard. For collimated beams, this warning shall state that viewing the laser output with certain instruments designed for use at a distance (for example telescopes and binoculars) may pose an eye hazard.

Wavelength = 1.3/1.5 μm .

Maximum power = 30 mW.

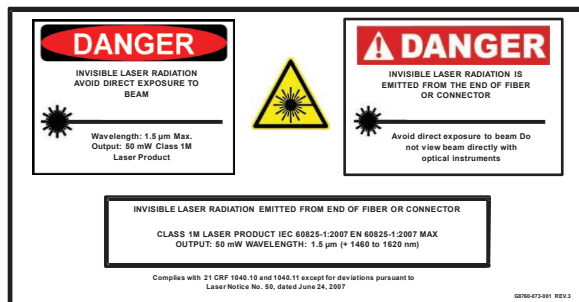

Caution Electrostatic Sensitivity



- Never touch laser diode and the module using hands
- Always use protections when handle a photodiode
- Recommend mounting the laser diode using an ionic gun and ESD finger cots

