

Terbium Gallium Garnet Based Polarization Independent 850/980/1060 Optical Circulator



(patents pending)

DATASHEET

BUY NOW



The OC Series Terbium Gallium Garnet Based 850/980/1060nm Optical Circulators are non-reciprocal devices that redirect light at 850/980/1060 nm from port-to-port in only one direction while minimizing back reflection and back scattering in the reverse directions for any state of polarization. With Agiltron's patent pending magnetic-optics technology and proven advanced micro optics design, the circulator features low insertion loss, high isolation, compact structure, high power handling, and high stability. The excellent characteristics of this product make it an ideal choice for application in fiber amplifier systems, pump laser diodes, and optical fiber sensors. Agiltron also provides customized design to meet special applications.

Features

- Low Insertion Loss
- High Isolation
- Low PDL
- High Stability
- High Reliability
- Cost Effective

Specifications

Parameter	Min	Typical	Max	Unit
Operation Wavelength	850	840	860	nm
	980	970	990	
	1060	1050	1070	
Insertion Loss ^[1]		1.0	1.5	dB
Wavelength Dependent Loss			0.2	dB
Isolation	20	25		dB
Polarization Dependent Loss		0.1	0.2	dB
Cross Talk	45	50		dB
Return Loss	50			dB
Optical Power Handling		500		mW
Storage Temperature	-10		60	°C
Fiber Type	See order information			

Notes:

[1]. Excluding connectors

Applications

- Optical Fiber Amplifier
- Pump Laser Source
- Fiber Optic Sensor
- Test and Measurement
- Instrumentation

Legal notices: All product information is believed to be accurate and is subject to change without notice. Information contained herein shall legally bind Agiltron only if it is specifically incorporated into the terms and conditions of a sales agreement. Some specific combinations of options may not be available. The user assumes all risks and liability whatsoever in connection with the use of a product or its application.

Rev 12/09/23

Terbium Gallium Garnet Based Polarization Independent 850/980/1060 Optical Circulator



(patents pending)

DATASHEET

Optical Performance

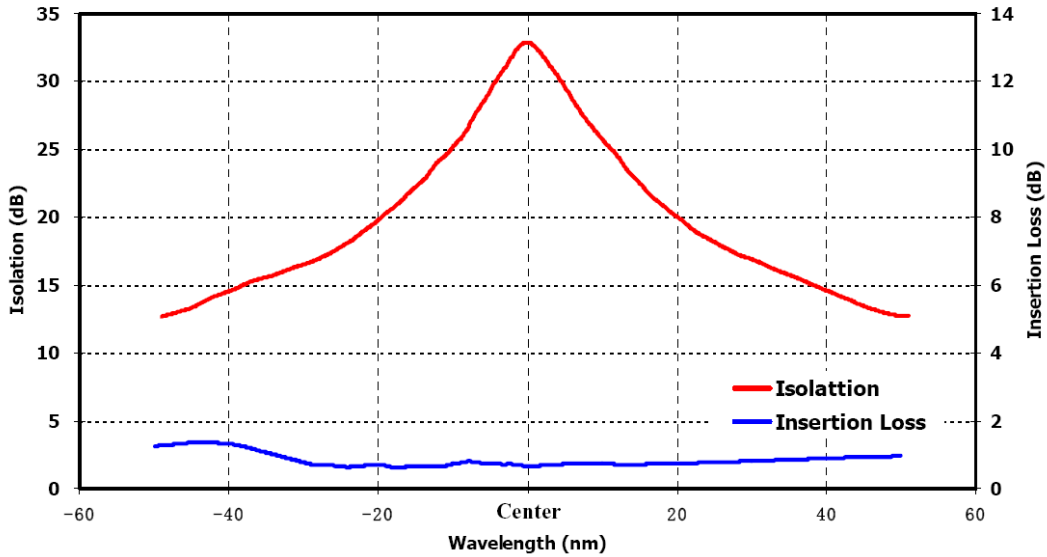

IL/Iso Vs. Temp @ Center Wavelength

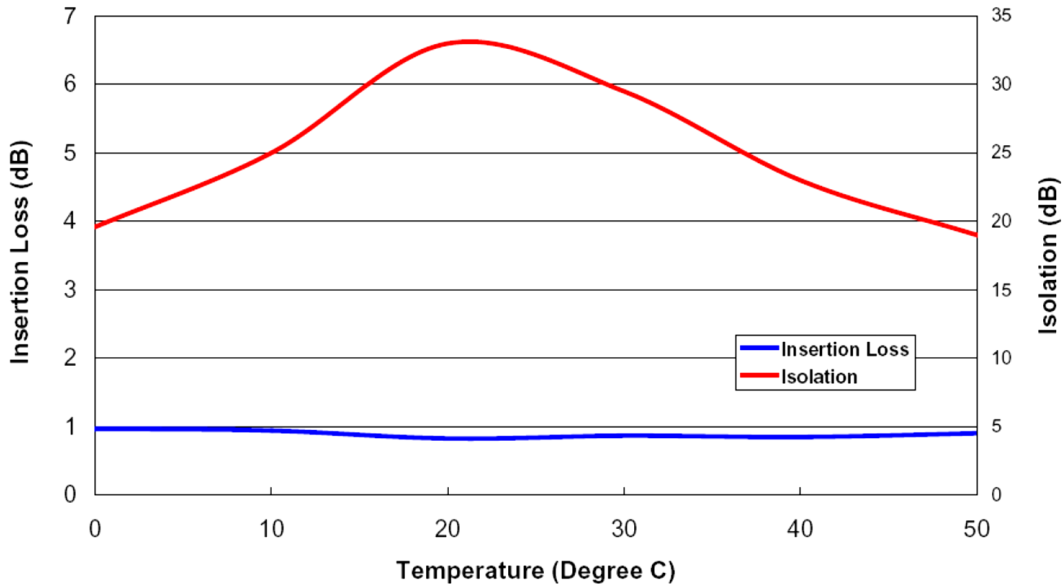

Terbium Gallium Garnet Based Polarization Independent 850/980/1060 Optical Circulator



(patents pending)

DATASHEET

Mechanical Dimensions (mm)

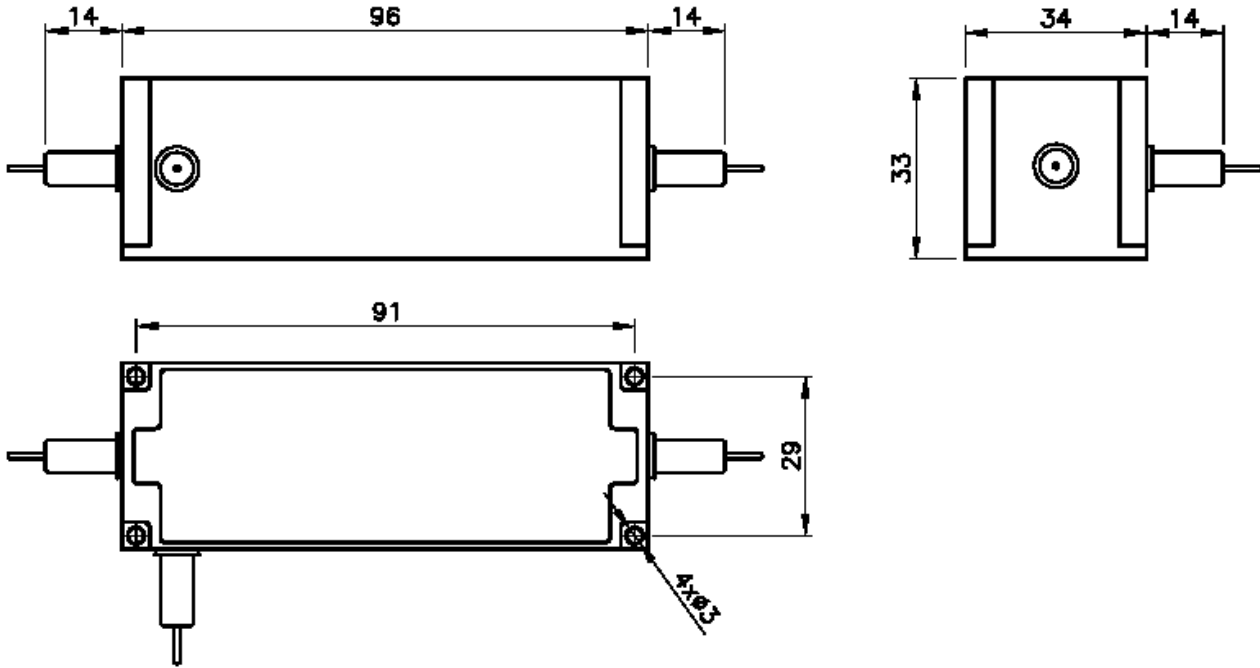

*Product dimensions may change without notice. This is sometimes required for non-standard specifications.

Ordering Information (Part Number)

Prefix	Type	Wavelength	Grade	Package	Fiber Type	Fiber Cover	Fiber Length	Connector ^[1]
OCST-	Polarization Independent = 11 Special = 10	1060 = 1 850 = 8 980 = 9 Special = 0	Standard = 1 Special = 0	Standard = 1 Special = 0	HI1060 = 2 HI1060 Flex = 3 HI780 = 7 HI980 = 9 Special = 0	Bare fiber = 1 900um Loose tube = 3 Special = 0	0.25m = 1 0.5m = 2 1.0m = 3 Special = 0	None = 1 FC/PC = 2 FC/APC = 3 SC/PC = 4 SC/APC = 5 ST/PC = 6 LC/PC = 7 LC/UPC = U Special = 0

[1]. The connector cannot be installed directly onto bare fiber, as it is prone to damage during shipping. However, the connector can be assembled on bare fiber if a 3 cm protective loose tube is added for reinforcement. The customer can remove this protective tube after testing. The optical power handling of a standard connector is less than 0.5 W for SM28 fiber and decreases further with smaller core fibers.