

TGG Based Polarization Independent Dual Stage 850/980/1060 Optical Circulator



(patents pending)

DATASHEET

BUY NOW



The OC Series Terbium Gallium Garnet Based 850/980/1060nm dual stage Optical Circulators are non-reciprocal devices that redirect light from port-to-port in only one direction while minimizing back reflection and back scattering in the reverse directions for any state of polarization. With Agiltron's patent pending magnetic-optics technology and proven advanced micro optics design, the dual stage circulator features low insertion loss, high isolation, broad wavelength coverage, high power handling, and high stability. Agiltron also provides customized design to meet special applications.

Features

- Low Insertion Loss
- High Isolation
- Low PDL
- High Reliability & Stability
- Broad Operation Wavelength

Specifications

Parameter	Min	Typical	Max	Unit
Operation Wavelength	850	840	860	nm
	980 ^[2]	970	990	
	1060	1050	1070	
Insertion Loss ^[1]		1.8	2.5	dB
Wavelength Dependent Loss			0.2	dB
Isolation	40	45	55	dB
Polarization Dependent Loss		0.15	0.25	dB
Cross Talk	45	50		dB
Return Loss	50	55		dB
Optical Power Handling		500	5000 ^[2]	mW
Storage Temperature	-10		60	°C
Fiber Type	See order information			

Notes:

- [1]. Excluding connectors
- [2]. Special order

Applications

- Fiber Optic Sensor
- Test and Measurement
- Instrumentation

Legal notices: All product information is believed to be accurate and is subject to change without notice. Information contained herein shall legally bind Agiltron only if it is specifically incorporated into the terms and conditions of a sales agreement. Some specific combinations of options may not be available. The user assumes all risks and liability whatsoever in connection with the use of a product or its application.

Rev 01/23/24

TGG Based Polarization Independent Dual Stage 850/980/1060 Optical Circulator



(patents pending)

DATASHEET

Optical Performance

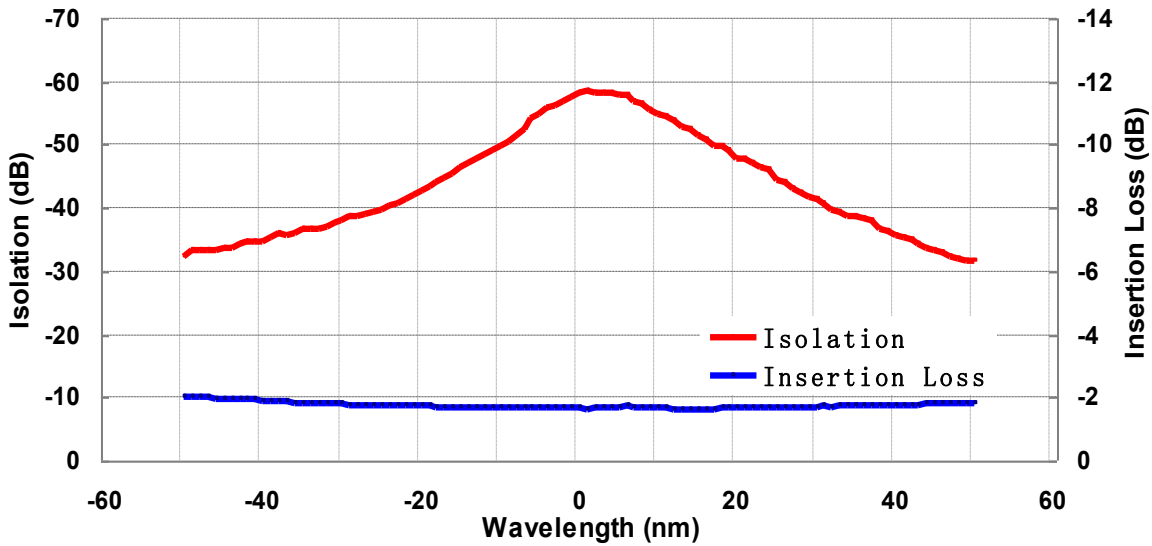

IL/ISO VS. Temp @ Center Wavelength

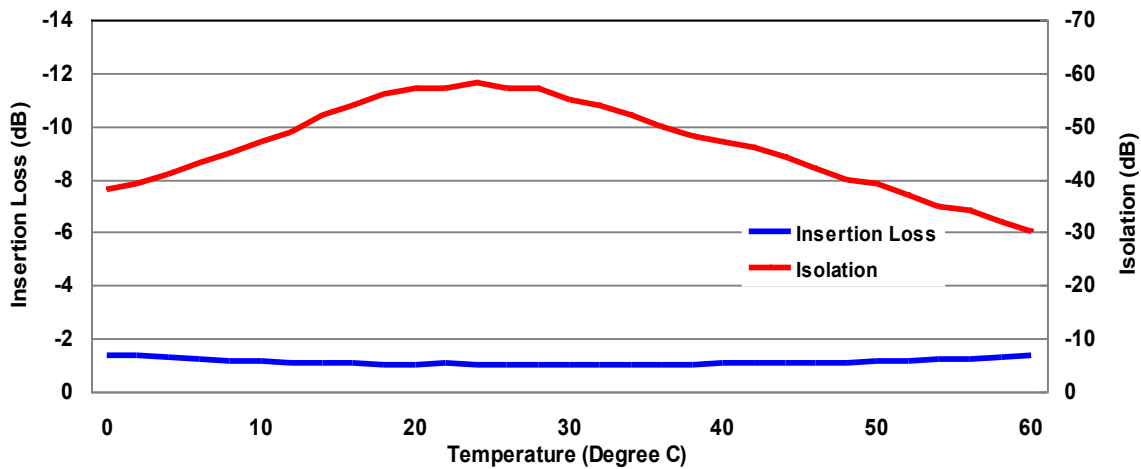

TGG Based Polarization Independent Dual Stage 850/980/1060 Optical Circulator



(patents pending)

DATASHEET

Mechanical Dimensions (mm)

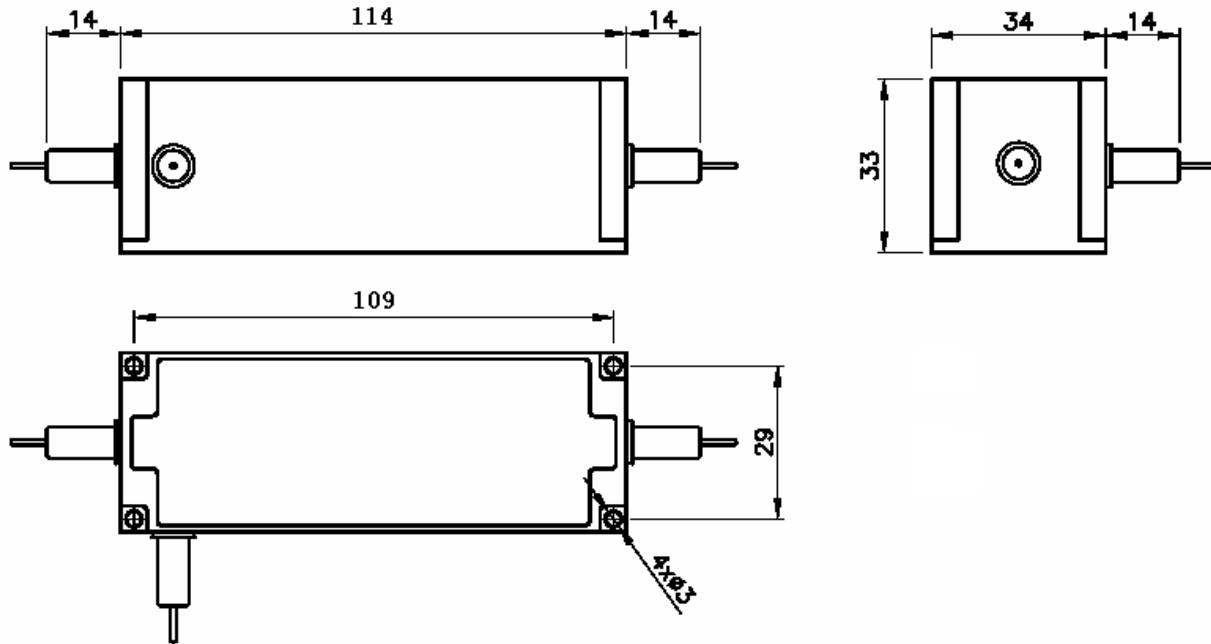

*Product dimensions may change without notice. This is sometimes required for non-standard specifications.

Ordering Information (Part Number)

Prefix	Type	Wavelength	Grade	Package	Fiber Type	Fiber Cover	Fiber Length	Connector ^[1]
OCST-	Polarization Independent = 11 Special = 10	1060 = 1 850 = 8 980 = 9 Special = 0	Standard = 1 Special = 0	Standard = 1 Special = 0	HI1060 = 2 HI1060 Flex = 3 HI780 = 7 HI980 = 9 Special = 0	Bare fiber = 1 900um Loose tube = 3 Special = 0	0.25m = 1 0.5m = 2 1.0m = 3 Special = 0	None = 1 FC/PC = 2 FC/APC = 3 SC/PC = 4 SC/APC = 5 ST/PC = 6 LC/PC = 7 LC/APC = A LC/UPC = U Special = 0

[1]. The connector cannot be installed directly onto bare fiber, as it is prone to damage during shipping. However, the connector can be assembled on bare fiber if a 3 cm protective loose tube is added for reinforcement. The customer can remove this protective tube after testing. The optical power handling of a standard connector is less than 0.5 W for SM28 fiber and decreases further with smaller core fibers.

TGG Based Polarization Independent Dual Stage 850/980/1060 Optical Circulator



(patents pending)

DATASHEET

Application Notes

Fiber Core Alignment

Note that the minimum attenuation for these devices depends on excellent core-to-core alignment when the connectors are mated. This is crucial for shorter wavelengths with smaller fiber core diameters that can increase the loss of many decibels above the specification if they are not perfectly aligned. Different vendors' connectors may not mate well with each other, especially for angled APC.

Fiber Cleanliness

Fibers with smaller core diameters ($<5 \mu\text{m}$) must be kept extremely clean, contamination at fiber-fiber interfaces, combined with the high optical power density, can lead to significant optical damage. This type of damage usually requires re-polishing or replacement of the connector.

Maximum Optical Input Power

Due to their small fiber core diameters for short wavelength and high photon energies, the damage thresholds for device is substantially reduced than the common 1550nm fiber. To avoid damage to the exposed fiber end faces and internal components, the optical input power should never exceed 20 mW for wavelengths shorter 650nm. We produce a special version to increase the handling by expanding the core side at the fiber ends.