

# CrystaLatch™ 1x1, 1x2 Fiber Optic Switch Single-Stage

(SM, PM, Unidirectional, Bidirectional)

(Protected by U.S. patents 7224860, 6757101, 6577430 and pending patents)



DATASHEET

[Return to the Webpage](#)

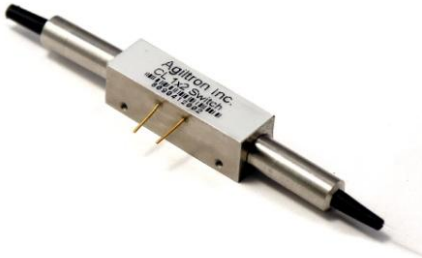

## Features

- Solid-State high speed
- Ultra-high reliability
- Fail-safe latching
- Low insertion loss
- Direct low voltage drive
- Compact
- Low cost

## Applications

- Optical channel blocking
- Configurable Add/Drop
- System monitoring
- Instrumentation



**Legal notices:** All product information is believed to be accurate and is subject to change without notice. Information contained herein shall legally bind Agiltron only if it is specifically incorporated into the terms and conditions of a sales agreement. Some specific combinations of options may not be available. The user assumes all risks and liability whatsoever in connection with the use of a product or its application.

Rev 01/28/26

The CL Series Fiber Optic Switch redirects an incoming optical signal into a selected output fiber, achieved using patented non-mechanical configurations and activated via an electrical control signal. Latching operation preserves the selected optical path after the drive signal has been removed. The all-solid-state CL fiber optic switch features low insertion loss, high extinction ratio, high channel isolation, and extremely high reliability and repeatability. Available configurations include polarization-independent; polarization-maintaining; bidirectional, and high power. It is designed to meet the most demanding switching requirements of continuous operation without failure, over 25-year longevity, operation under shock/vibration environment and large temperature variations, and fast response time.

The switch also has circulator and isolator functions. An electronic driver is available for this series of switches.

The magneto-optical crystals used in the CL switches have no fatigue nor drift effect.

## Specifications

Parameter	Min	Typical	Max	Unit
Operation Wavelength <sup>[1]</sup>	1520	1550	1580	nm
	1295	1310	1325	
Insertion Loss <sup>[2]</sup>		0.7	1.0 (1.2 <sup>[4]</sup> )	dB
Cross Talk	Bidirectional	18	25	dB
	Unidirectional	20	28	dB
Return Loss	50	55		dB
PDL (SM Series)		0.1	0.2	dB
Extinction Ratio (PM Series)	18	25		dB
Optical Switching Speed (rise, fall)	5		10	µs
Repetition Rate		2K		Hz
Polarization Mode Dispersion		0.1	0.2	ps
Operating Temperature	-5		70	°C
Storage Temperature	-40		85	°C
Optical Power Handling <sup>[3]</sup>		200	300	mW
Durability	10 <sup>15</sup>			cycles

### Notes:

- [1]. Agiltron can achieve the same SPEC at the L band.
- [2]. Measured without connectors. Each connector adds 0.3dB
- [3]. Special operating temperature -40 to +85 °C is available with Ordering Information (Part Number).
- [4]. For special operating temperatures, lower than -20 °C and higher than +70 °C.

**Note:** The specifications provided are for general applications with a cost-effective approach. If you need to narrow or expand the tolerance, coverage, limit, or qualifications, please [click this link](#):

P +1 781-935-1200

E [sales@agiltron.com](mailto:sales@agiltron.com)

W [www.agiltron.com](http://www.agiltron.com)

# CrystaLatch™ 1x1,1x2 Fiber Optic Switch Single-Stage

(SM, PM, Unidirectional, Bidirectional)

(Protected by U.S. patents 7224860, 6757101, 6577430 and pending patents)



## DATASHEET

### Mechanical Dimensions (Unit: mm)

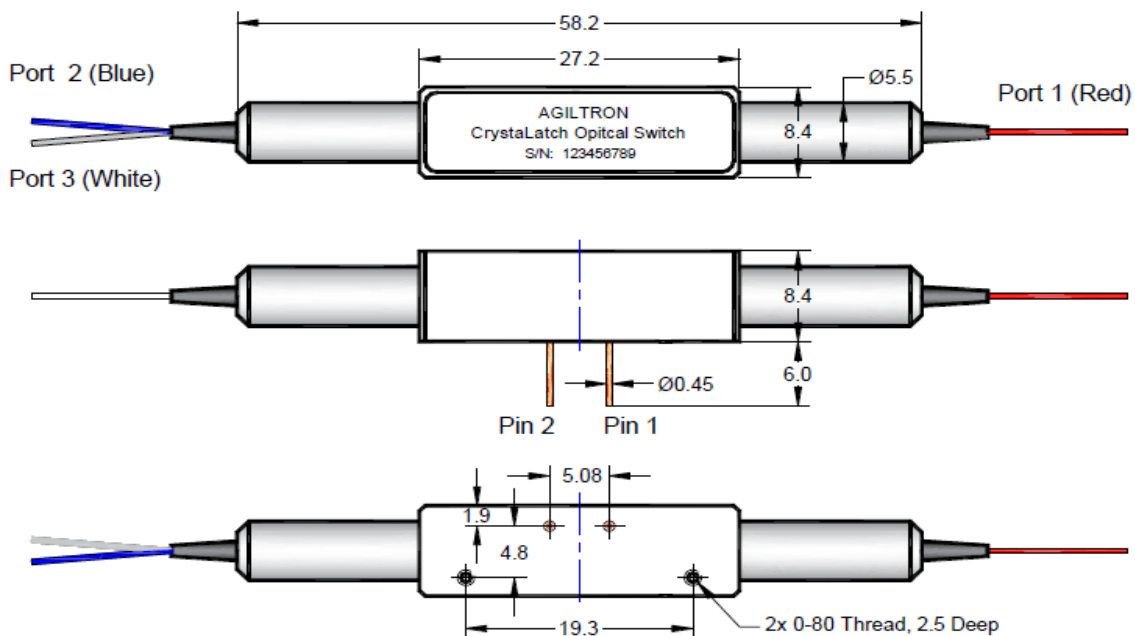

\*Product dimensions may change without notice. This is sometimes required for non-standard specifications.

# CrystaLatch™ 1x1, 1x2 Fiber Optic Switch Single-Stage

(SM, PM, Unidirectional, Bidirectional)

(Protected by U.S. patents 7224860, 6757101, 6577430 and pending patents)



## DATASHEET

### Electrical Driving Information

The switch is actuated by applying a voltage pulse. Applying one polarity pulse, one light path will be connected and latched to the position. Applying a reversed polarity pulse, another light path will be connected and latched to the position after pulse removed.

Parameter	Minimum	Typical	Maximum	Unit
Drive Voltage	2.25	2.5	2.75	V
Resistance (Pin 1 – Pin 2)	15	18	22	Ω
Pulse Duration	0.2	0.3	0.5	ms

Driving PCB with RS232, USB, TTL, and Windows™ GUI is available.

#### Bidirectional Series 1x1, 1x2 or 2x1 Switch Driving Table

Optical Path		Pin 1	Pin 2
1x1	1x2 or 2x1		
Port 1 ↔ Port 2	Port 1 ↔ Port 2	0	+
Dark	Port 1 ↔ Port 3	+	0

“+” is high voltage pulse, “0” is zero voltage.

#### Unidirectional Series 1x1, 1x2 Switch Driving Table

Optical Path		Pin 1	Pin 2
1x1	1x2		
Port 1 → Port 2	Port 1 → Port 2	0	+
Dark	Port 1 → Port 3	+	0

“+” is high voltage pulse, “0” is zero voltage.

#### Unidirectional Series 1x1, 2x1 Switch Driving Table

Optical Path		Pin 1	Pin 2
1x1	2x1		
Port 2 → Port 1	Port 2 → Port 1	+	0
Dark	Port 3 → Port 1	0	+

“+” is high voltage pulse, “0” is zero voltage.

#### Note:

The driving voltage value is transient voltage with a full load. The driver circuitry needs to provide sufficient current (~300mA) during the switching. Inside the switch core is an electromagnet with a residual magnetic field. The residual magnetic field will be established when an electrical current flows in one direction through the coil for a sufficiently long period. The residual magnetic field latches the switch state even without applying a voltage (the current flow stopped). Flowing a current in the opposite direction for a sufficient time changes the switch stage by establishing a reversal magnetic field. The coil is forgiving to the driver unless one burns it by applying a higher voltage or a current for too long (day). The switch can also be operated at high repetition rates of kHz, where the residual magnetic field may not be fully established.

# CrystaLatch™ 1x1, 1x2 Fiber Optic Switch Single-Stage

(SM, PM, Unidirectional, Bidirectional)

(Protected by U.S. patents 7224860, 6757101, 6577430 and pending patents)



## DATASHEET

### Typical Switching Response

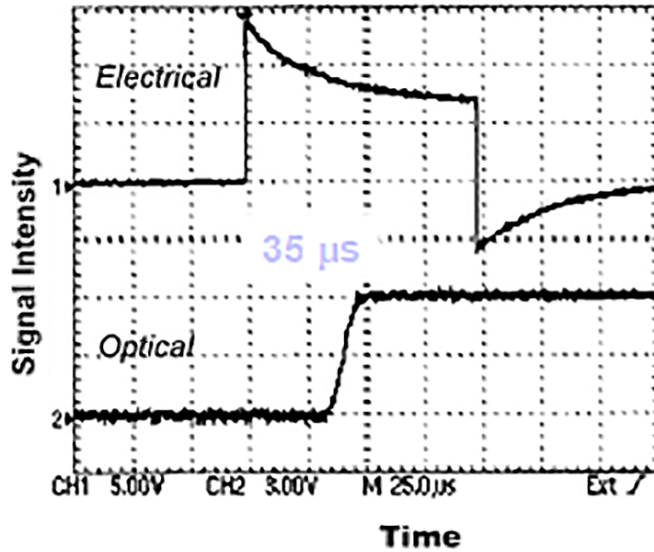

### Typical Loss Change of 1x2 vs Switching Numbers

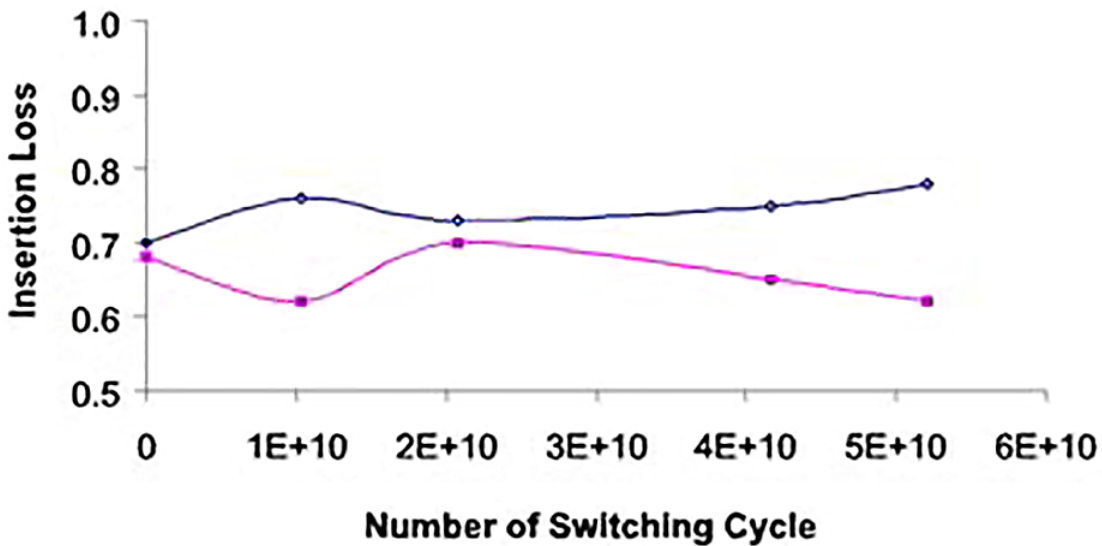

# CrystaLatch™ 1x1, 1x2 Fiber Optic Switch Single-Stage

(SM, PM, Unidirectional, Bidirectional)

(Protected by U.S. patents 7224860, 6757101, 6577430 and pending patents)



## DATASHEET

### Functional Diagram

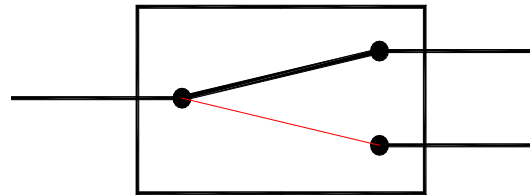

CL 1x2 Series Switch

### Ordering Information (Part Number)

Prefix	Type	Wavelength	Switch	Package	Fiber Type	Fiber Cover	Fiber Length	Connector <sup>[5][7]</sup>
<b>CLSW</b> - <sup>[1]</sup>	1x1 = 11	1310 = 3	Single Stage <sup>[6]</sup> = 1	Standard = 3	SMF-28 = 1	Bare fiber = 1	0.25m = 1	None = 1
<b>CLPM</b> - <sup>[2]</sup>	1x2 = 12	1550 = 5	Special = 0	-40~+85°C = A	PM 1550 = B	900 um tube = 3	0.5m = 2	FC/PC = 2
<b>CLBD</b> - <sup>[3]</sup>	2x1 = 21	Special = 0		-40~+70°C = B	PM 1310 = D	Special = 0	1.0m = 3	FC/APC = 3
<b>CLPB</b> - <sup>[4]</sup>	Special = 00			-20~+85°C = C	Special = 0		Special = 0	SC/PC = 4
				-20~+70°C = D				SC/APC = 5
				Special = 0				ST/PC = 6
								LC/PC = 7
								Duplex LC/PC = 8
								LC/APC = A
								LC/UPC = U
								Special = 0

[1]. **CLSW**: CrystaLatch 1x1, 1x2 SM SWITCH.

[2]. **CLPM**: CrystaLatch 1x1, 1x2 PM Switch.

[3]. **CLBD**: CrystaLatch 1x1, 1x2 SM BIDIRECTIONAL Switch.

[4]. **CLPB**: CrystaLatch 1x1, 1x2 PM Bidirectional Switch.

[5]. There isn't any connector in high power switches. Please contact us for high power connectors.

[6]. Using one switching cores for low cost

[7]. The connector cannot be installed directly onto bare fiber, as it is prone to damage during shipping. However, the connector can be assembled on bare fiber if a 3 cm protective loose tube is added for reinforcement. The customer can remove this protective tube after testing. The optical power handling of a standard connector is less than 0.5 W for SM28 fiber and decreases further with smaller core fibers.

#### Fiber Core Alignment

Note that the minimum attenuation for these devices depends on excellent core-to-core alignment when the connectors are mated. This is crucial for shorter wavelengths with smaller fiber core diameters that can increase the loss of many decibels above the specification if they are not perfectly aligned. Different vendors' connectors may not mate well with each other, especially for angled APC.

#### Fiber Cleanliness

Fibers with smaller core diameters (<5 μm) must be kept extremely clean, contamination at fiber-fiber interfaces, combined with the high optical power density, can lead to significant optical damage. This type of damage usually requires re-polishing or replacement of the connector.

#### Maximum Optical Input Power

Due to their small fiber core diameters for short wavelength and high photon energies, the damage thresholds for device is substantially reduced than the common 1550nm fiber. To avoid damage to the exposed fiber end faces and internal components, the optical input power should never exceed 20 mW for wavelengths shorter 650nm. We produce a special version to increase the how handling by expanding the core side at the fiber ends.

# CrystaLatch™ 1x1,1x2 Fiber Optic Switch Single-Stage

(SM, PM, Unidirectional, Bidirectional)

(Protected by U.S. patents 7224860, 6757101, 6577430 and pending patents)



## DATASHEET

### Driver Design Example for 1x4

A recommended +5VDC powered driving circuit is provided. The resistor network R1~R8 is to suppress the driving signal's voltage level to meet the "switch voltage" requirements. In specific applications, users can use lower voltage to eliminate the R1~R8. The Q1~Q8 is the control signal from either a function generator or a microcontroller general purpose I/O. The Q1~Q8 switching speed must meet the specific MOSFET switching requirement and CL 1x4 Switch specific requirement. Usually, the control signal speed is  $\leq 2\text{kHz}$ .

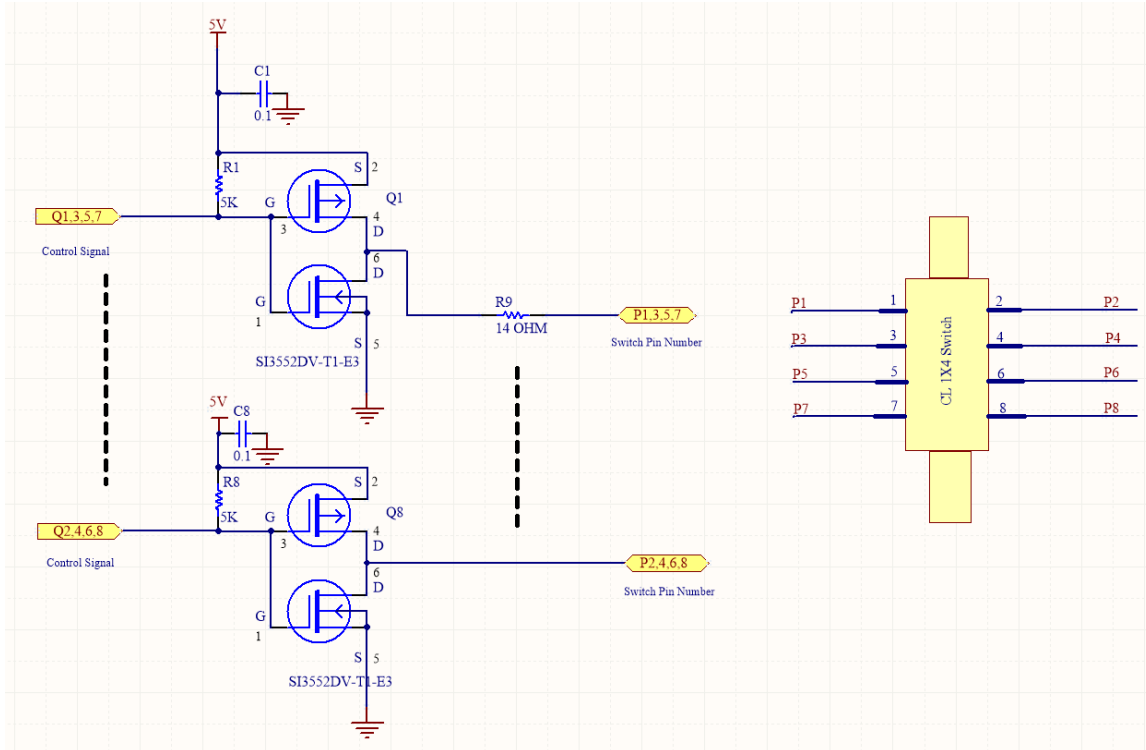

Usually, a clean power supply source will be sufficient. However, decoupling capacitors for the transistor supply rail are recommended depending on different applications. Minimum the current loop on the switching circuits will minimize the switching noise. For other layout recommendations, please refer to books or application notes from the IC manufacturer.