

BUY NOW



CrystaLatch™ 1x2 Multicasting Solid-State Fiberoptic Switch

(Protected by U.S. patents 7224860, 6757101, 6577430 and pending patents)

Product Description

The CL Series 1x2 Multicasting fiber optical switch connects optical channels by redirecting an incoming optical signal either into a selected output fiber or splitting equally into the two output fibers. This is achieved using patented non-mechanical configurations and activated via an electrical control signal. Latching operation preserves the selected optical path after the drive signal has been removed. The all solid state CL 1x2 Multicasting fiberoptic switch features low insertion loss, high extinction ratio, high channel isolation, and extremely high reliability and repeatability. It is designed to meet the most demanding switching requirements of continuous operation without failure, longevity, operation under shock/vibration environment and large temperature variations, and fast response time.

The switch also has build-in circulator and isolator functions. Electronic driver is available for this series of switches.



Performance Specifications

CL Series 1x2 Switch	Min	Typical	Max	Unit
Operation Wavelength ¹	1520	1550	1580	nm
	1295	1310	1325	nm
Insertion Loss ²	0.4	0.7	1.0	dB
Cross Talk	20	28		dB
Splitting power difference	0	0.15	0.5	dB
Switch Speed (rise, fall)	5	50	200	µs
Repetition Rate		2K		Hz
Durability	10 ¹⁴			cycle
Polarization Dependent Loss		0.05	0.20	dB
Polarization Mode Dispersion		0.1	0.2	ps
Return Loss ²	50	55	60	dB
Operating Temperature	-5 ³		70	°C
Optical Power Handling ^{4,5}		300		mW
Storage Temperature	-40		85	°C
Fiber Type	Corning SMF-28			
Package Dimension	74.6L x 8.4W x 8.6H			mm

1. Agiltron can achieve same SPEC at L band
2. Exclude connectors
3. -40°C version is also available.
4. High power version available.
5. Continuous operation, for pulse operation call.

Features

- Solid-State high speed
- Ultra-high reliability
- Fail-safe latching
- Low insertion loss
- Direct low voltage drive
- Compact
- Low cost

Applications

- Optical channel blocking
- Configurable Add/Drop
- System monitoring
- Instrumentation

CrystaLatch™ 1x2 Multicasting Solid-State Fiberoptic Switch

Electrical Driving Information

The switch is actuated by applying a voltage pulse. Applying one polarity pulse, one light path will be connected and latched to the position. Applying a reversed polarity pulse, another light path will be connected and latched to the position after pulse removed.

Parameter	Minimum	Typical	Maximum	Unit
Drive Voltage	2.25	2.5	2.75*	V
Drive Current	110	140	195	mA
Pulse Duration	0.2	0.3	0.5	ms

*Over this value will damage the device.

Driving kit with USB and TTL interfaces and Windows™ GUI is available. We also offer RS232 interface as an option - please contact Agiltron sales.

CL 1x2 Multicasting Switch

Optical Path	Pin Group 1		Pin Group 2	
	Pin 1	Pin 2	Pin 3	Pin 4
Port 1→Port 2	2.5V Pulse	GND	2.5V Pulse	GND
Port 1→Port 3	GND	2.5V Pulse	GND	2.5V Pulse
Multicasting	2.5V Pulse	GND	GND	2.5V Pulse

Mechanical Dimensions (mm)

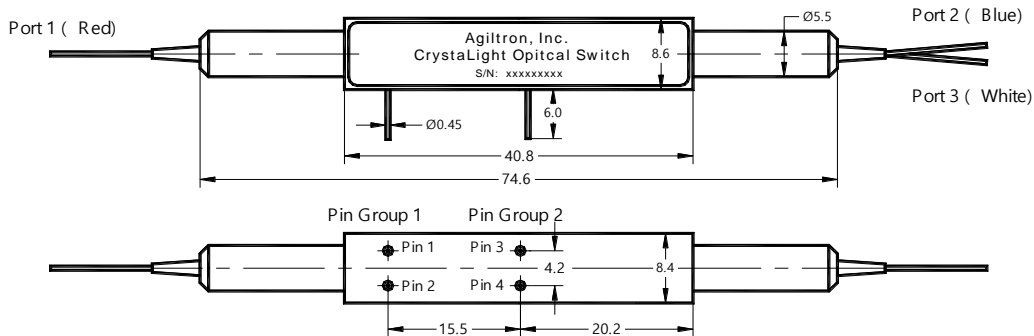

*Product dimensions may change without notice. This is sometimes required for non-standard specifications.

Ordering Information

CLSW-	<input type="checkbox"/>	<input type="checkbox"/>	<input type="checkbox"/>	<input type="checkbox"/>	<input type="checkbox"/>	<input type="checkbox"/>	<input type="checkbox"/>	<input type="checkbox"/>
Type	Wavelength	Switch	Package	Fiber Type	Fiber Length	Connector		
	1310=3 1550=5	Standard=1 Special=0	Standard=1 Special=0	SMF-28=1 Special=0	Bare fiber=1 900µm loose tube=3 Special=0	0.25m=1 0.5m=2 1.0m=3 Special=0	None=1 FC/PC=2 FC/APC=3 SC/PC=4 SC/APC=5 ST/PC=6 LC=7 Duplex LC=8 Special=0	