

High Power Optical Connectors (50W)

(Copper Ferrule, Free Fiber Tip, Epoxy Free Connector)



DATASHEET

BUY NOW

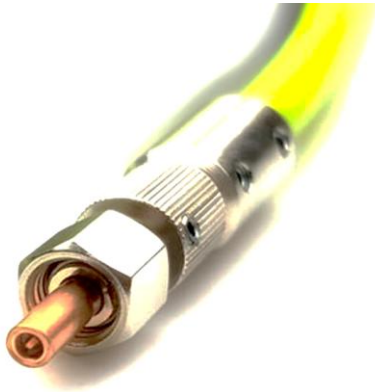

Our high-power connectors incorporate several advantageous features. It uses copper ferrules with bored front to better dissipation heat and free-standing fiber tip to minimize the probability of damage of uncoupled light. The front part of the connector is epoxy free to prevent burning. It has key pin so that each connector can be pre-aligned to achieve and ensure uniform low loss. AR coating is an option to further reduce the loss and increase reliability. Moreover, we offer mode-stripping which removes most of the light from fiber cladding. We further offer fiber end-cap enhancement of these connectors for higher power handling, which expands the Mode Field Diameter and thus reduces the power density at the glass-air interface to a level below the damage threshold

Features

- Key Pin Aligned
- Copper Ferrule
- Free Fiber Tip
- AR Coating
- Mode-Stripping
- PVC Tubing
- Metal Tubing

Applications

- Laser Cutting
- Laser process

Specifications

Parameter	Min	Typical	Max	Unit
Fiber Core Diameter	105		1000	μm
Operating Wavelength	400		2400	nm
Numerical Aperture (Typical)		0.22		
Storage Temperature	-40		85	°C
Mirror Size		1"		

Note: The specifications provided are for general applications with a cost-effective approach. If you need to narrow or expand the tolerance, coverage, limit, or qualifications, please [click this link](#):

Legal notices: All product information is believed to be accurate and is subject to change without notice. Information contained herein shall legally bind Agiltron only if it is specifically incorporated into the terms and conditions of a sales agreement. Some specific combinations of options may not be available. The user assumes all risks and liability whatsoever in connection with the use of a product or its application.

Rev 08/23/24

© Photonwares Corporation

P +1 781-935-1200

E sales@photonwares.com

W www.agiltron.com

Information contained herein is deemed to be reliable and accurate as of the issue date. Photonwares reserves the right to change the design or specifications at any time without notice. Agiltron is a registered trademark of Photonwares Corporation in the U.S. and other countries.

High Power Optical Connectors (50W)

(Copper Ferrule, Free Fiber Tip, Epoxy Free Connector)



DATASHEET

Special SMA Connectors Dimensions (mm)

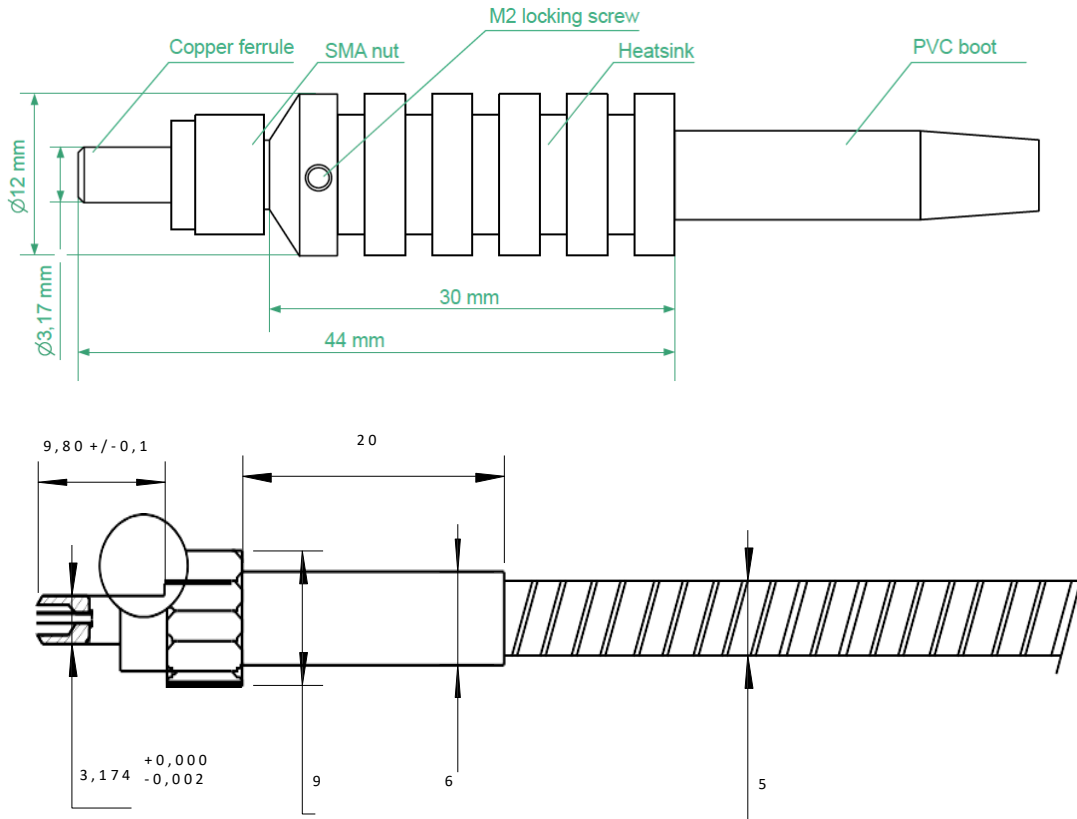

*Product dimensions may change without notice. This is sometimes required for non-standard specifications.

High Power Optical Connectors (50W)

(Copper Ferrule, Free Fiber Tip, Epoxy Free Connector)



DATASHEET

Ordering Information (Part Number) System

Prefix	Type	Wavelength AR Coating	End Cap	Heat Sink	Fiber Type	Cable Type	Fiber	0
HPCT-	SMA905 = 01 SMA980 = 02 SMA = 03	None = 0 488 = 4 532 = 5 650 = 6 780 = 7 850 = 8 980 = 9 1060 = 1 1310 = 3 1550 = C 2000 = 2	No = 0 Yes = 1	No = 0 Yes = 1	Step Index = 1 Graded Index = 2	PVC = 1 Metal = 2	105/125 = 1 100/600 = 2 200/220 = 3 200/280 = 4 400/440 = 5 400/480 = 6 600/720 = 7 800/880 = 8 1000/1100 = 9	

* Default is 1 pair of jumper cable, each 1m length, both ends with same connector type as on box panel

Use "0" for special need and describe all details clearly in order.

Application Notes

Fiber Core Alignment

Note that the minimum attenuation for these devices depends on excellent core-to-core alignment when the connectors are mated. This is crucial for shorter wavelengths with smaller fiber core diameters that can increase the loss of many decibels above the specification if they are not perfectly aligned. Different vendors' connectors may not mate well with each other, especially for angled APC.

Fiber Cleanliness

Fibers with smaller core diameters (<5 μm) must be kept extremely clean, contamination at fiber-fiber interfaces, combined with the high optical power density, can lead to significant optical damage. This type of damage usually requires re-polishing or replacement of the connector.

Maximum Optical Input Power

Due to their small fiber core diameters for short wavelength and high photon energies, the damage thresholds for device is substantially reduced than the common 1550nm fiber. To avoid damage to the exposed fiber end faces and internal components, the optical input power should never exceed 20 mW for wavelengths shorter 650nm. We produce a special version to increase the handling by expanding the core side at the fiber ends.