

# High Power 850/980/1060 Optical Circulator



(patents pending)

DATASHEET

BUY NOW



The OC Series High Power 850/980/1060nm Optical Circulator is non-reciprocal device designed for high power applications, it redirect light at 850/980/1060 nm from port-to-port in only one direction while minimizing back reflection and back scattering in the reverse directions for any state of polarization. With Agiltron's proprietary in-fiber beam expansion technology that scale down the power density, the OC Series High Power Circulator can intrinsic handle optical power beyond 20W, all devices are tested under high power before shipping. With Agiltron's patent pending magnetic-optics technology and proven advanced micro optics design, the circulator features low insertion loss, high isolation, compact structure, high power handling, and high stability. The excellent characteristics of this product make it an ideal choice for application in fiber amplifier systems, pump laser diodes, and optical fiber sensors. Agiltron also provides customized design to meet special applications.

## Features

- Low Insertion Loss
- High Isolation
- Low PDL
- High Stability
- High Reliability
- Cost Effective

## Specifications

Parameter		Min	Typical	Max	Unit
Operation Wavelength	850	840		860	nm
	980	970		990	
	1060	1050		1070	
Insertion Loss <sup>[1]</sup>			1.2	1.6	dB
Wavelength Dependent Loss				0.2	dB
Isolation		20	25		dB
Polarization Dependent Loss			0.1	0.2	dB
Cross Talk		45	50		dB
Return Loss		50			dB
Optical Power Handling <sup>[2]</sup>				20	W
Storage Temperature		-10		60	°C
Fiber Type		See order information			

### Notes:

[1]. Excluding connectors

[2]. Continuous operation, for pulse operation call

## Applications

- Optical Fiber Amplifier
- Pump Laser Source
- Fiber Optic Sensor
- Test and Measurement
- Instrumentation

**Legal notices:** All product information is believed to be accurate and is subject to change without notice. Information contained herein shall legally bind Agiltron only if it is specifically incorporated into the terms and conditions of a sales agreement. Some specific combinations of options may not be available. The user assumes all risks and liability whatsoever in connection with the use of a product or its application.

Rev 08/15/24

# High Power 850/980/1060 Optical Circulator



(patents pending)

## DATASHEET

### Optical Performance

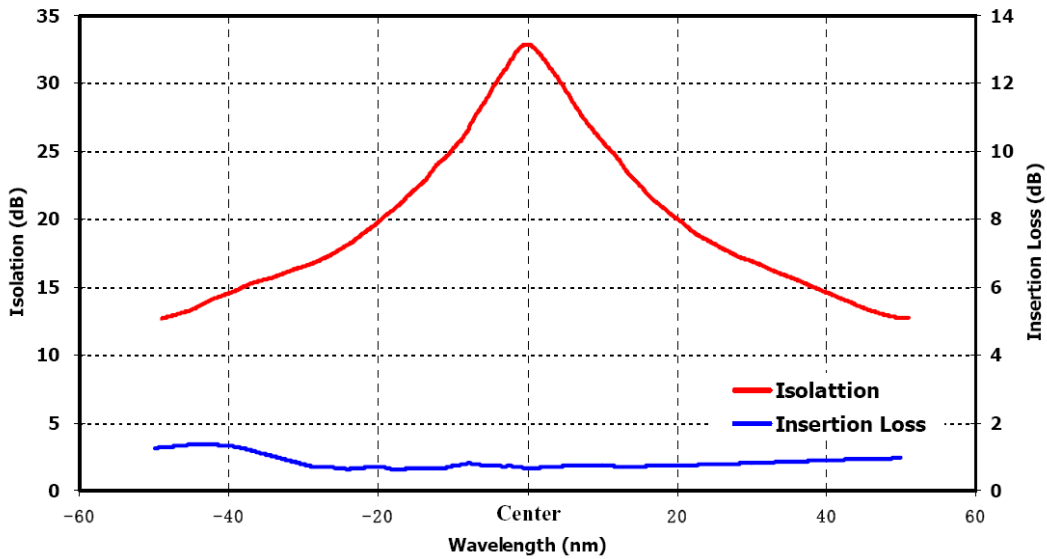

IL/Iso Vs. Temp @ Center Wavelength

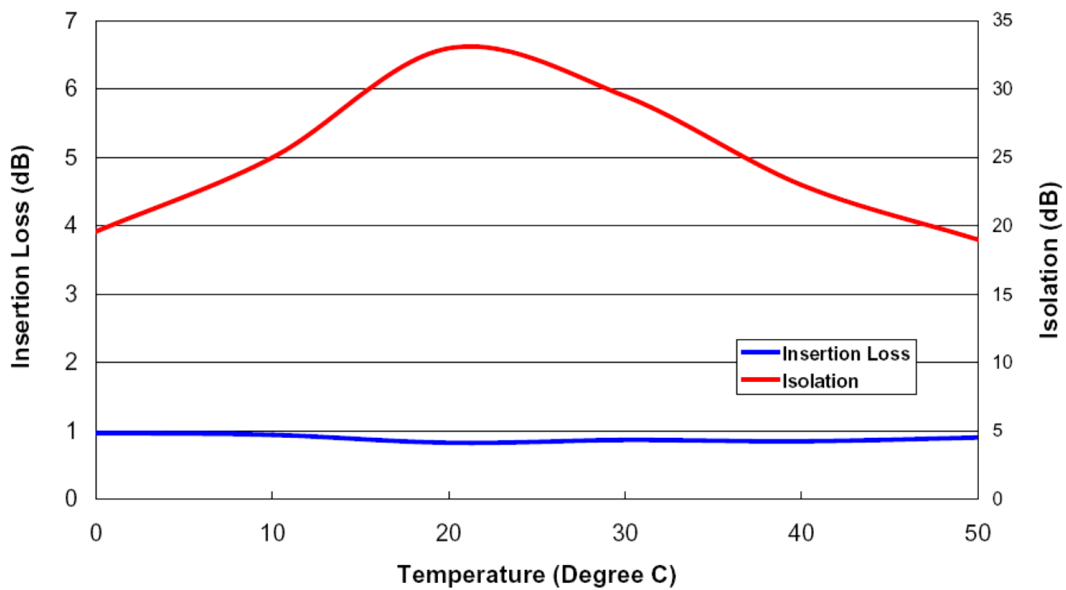

# High Power 850/980/1060 Optical Circulator



(patents pending)

## DATASHEET

### Mechanical Dimensions (mm)

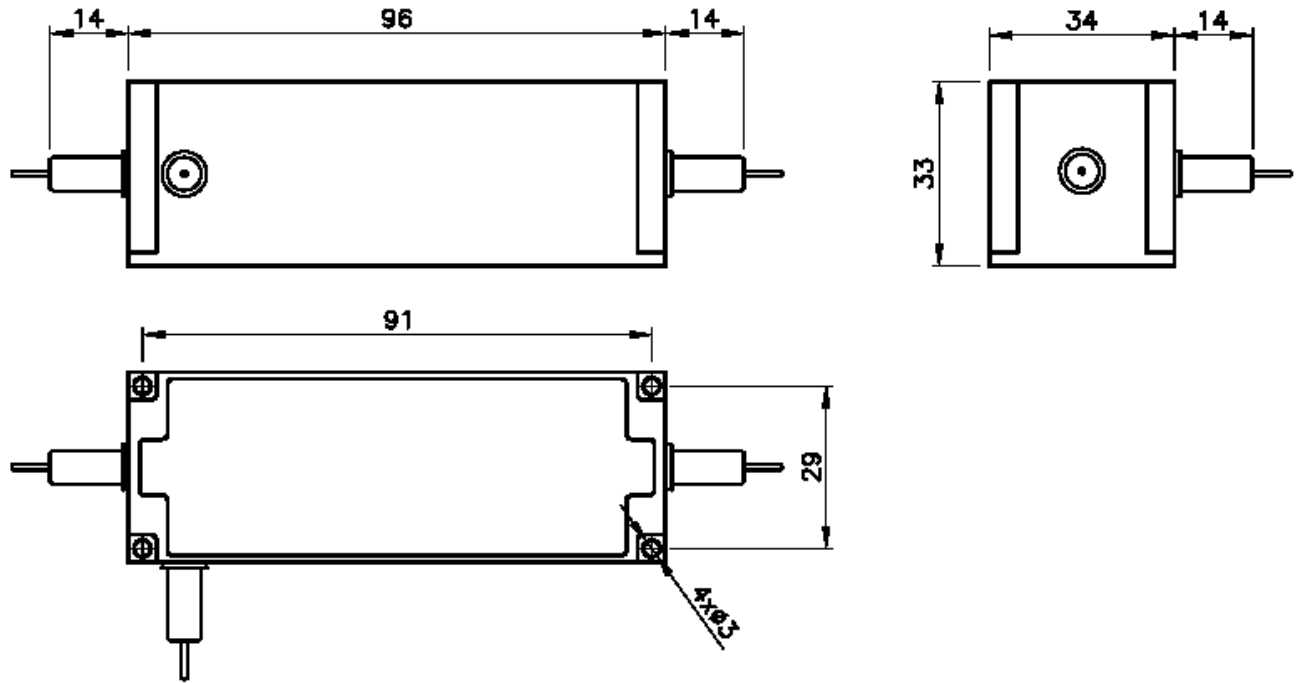

\*Product dimensions may change without notice. This is sometimes required for non-standard specifications.

### Ordering Information (Part Number)

Prefix	Type	Wavelength	Grade	Package	Fiber Type	Fiber Cover	Fiber Length	Connector
								1 *
OCST-	HP Polarization Independent = 31 HP Polarization Maintaining = 32 Special = 30	1060 = 1 1030 = 2 850 = 8 980 = 9 Special = 0	1W = 1 2W = 2 5W = 5 10W = 6 20W = 7	Standard = 1 Special = 0	HI1060 = 2 HI980 = 9 PM980 = E Special = 0	Bare fiber = 1 900um Loose tube = 3 Special = 0	0.25m = 1 0.5m = 2 1.0m = 3 Special = 0	

\* Agiltron provide high power connector, please call.

[1]. The connector cannot be installed directly onto bare fiber, as it is prone to damage during shipping. However, the connector can be assembled on bare fiber if a 3 cm protective loose tube is added for reinforcement. The customer can remove this protective tube after testing. The optical power handling of a standard connector is less than 0.5 W for SM28 fiber and decreases further with smaller core fibers.