

Fiber Phase Shifter – Piezoelectric

Up to 8π , 400nm to 2600nm

DATASHEET

[Return to the Webpage](#)



Features

- Large Phase Shift
- High Reliability
- Low Insertion Loss
- Compact Size
- High Optical Power Handling

Applications

- Fiber Sensor
- Fiber Interferometer
- Fiber Laser
- Instrumentation

The Piezoelectric Fiber Phase Shifter (PIPS) employs a piezoelectric fiber stretcher to induce birefringence and achieve phase retardation. It features ultra-low insertion loss, compatibility with all fiber types, high power handling, and significant phase-shifting capability. Two configurations are available: the straight version, offering phase shifts up to 8π , and the coil version, achieving phase shifts up to 50π . Designed for fast response and continuous operation, the PIPS excels in large-scale fiber phase-shifting applications.

A dedicated driver with 0–5V input control and a frequency range of up to 100 kHz enables seamless system integration. Control signals are applied via an SMA connector, and the driver is powered by a 12V DC supply (included). Each unit is rigorously tested to ensure optimal performance. Significant phase shifts can be achieved at resonance frequencies, optimizing power consumption for applications demanding significant phase modulation. The PIPS offers a cost-effective, robust, high-performance solution for advanced fiber phase-shifting needs.

Specifications

Parameter	Min	Typical	Max	Unit
Wavelength	400		2650	nm
Insertion Loss ^[1]	0.1	0.5	0.8	dB
Polarization Mode Dispersion			0.05	ps
Return Loss	65			dB
Response Time Rise/Fall	30			μs
Operating Optical Power		0.5	1	W
Operation Frequency	DC		1	kHz
Resonance Frequency		35		kHz
Residual Amplitude Modulation			0.02	dB
Phase Change ^[2]	0		8	π
Control Voltage ^[2]	0	20	150	V
Capacitance of Piezo	2	5	12	nF
Operating Temperature		0 ~ 60		°C
Storage Temperature		-40 ~ 85		°C

Notes:

[1]. Excluding connectors. Connectors add 0.3dB.

[2]. @1550nm

Legal notices: All product information is believed to be accurate and is subject to change without notice. Information contained herein shall legally bind Agiltron only if it is specifically incorporated into the terms and conditions of a sales agreement. Some specific combinations of options may not be available. The user assumes all risks and liability whatsoever in connection with the use of a product or its application.

Rev 12/16/24

Fiber Phase Shifter – Piezoelectric

Up to 8π , 400nm to 2600nm

DATASHEET

Mechanical Dimensions (inch)

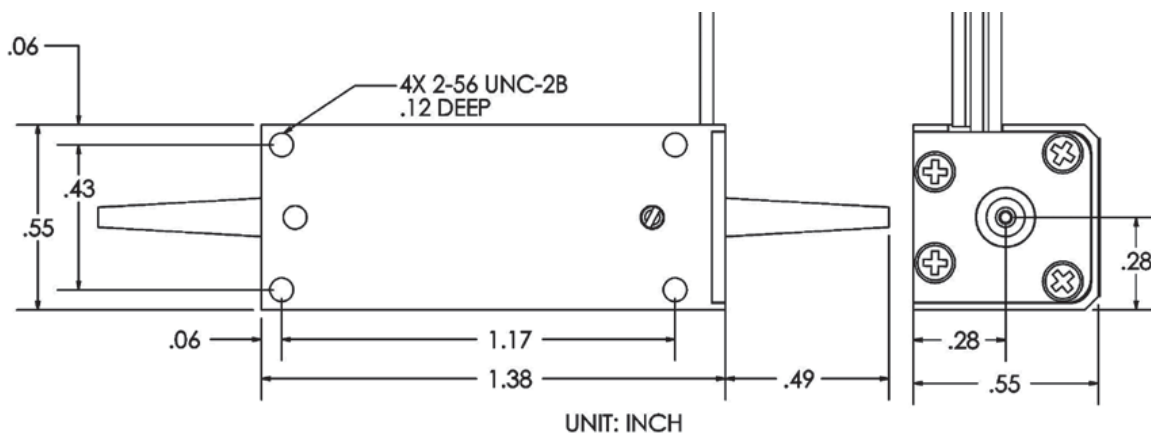

*Product dimensions may change without notice. This is sometimes required for non-standard specifications.

Electrical Driver Pin Definition

Pin #	Connection
1	+
2	-

Fiber Phase Shifter – Piezoelectric

Up to 8π, 400nm to 2600nm

DATASHEET

Ordering Information

Prefix	Type	Test Wavelength	Driver	Fiber Type	Fiber Cover *	Fiber Length	Connector
PIPS-		360 nm = A 430 nm = B 488 nm = 4 532 nm = 5 630 nm = 6 780 nm = 7 850 nm = 8 980 nm = 9 1060 nm = 1 1310 nm = 3 1550 nm = C 2000 nm = 2 2.3-4.1 μm = F	Non = 1 Yes = 2 Special = 0	Select Below	0.9mm Tube = 1 Bare Fiber = 2 Special = 0	0.25m = 1 0.5m = 2 1.0 m = 3 Special = 0	None = 1 FC/PC = 2 FC/APC = 3 LC/PC = L Special = 0

* Bare fiber can not put on connectors due to its fragility

Fiber Type Selection Table:

01	SMF-28	34	PM1550	71	MM 50/125μm
02	SMF-28e	35	PM1950	72	MM 62.5μm
03	Corning XB	36	PM1310	73	105/125μm
04	SM450	37	PM400	74	FG105LCA
05	SM1950	38	PM480	75	FG50LGA
06	SM600	39	PM630	76	STP 50/125
07	780HP	40	PM850	77	IRZS23
08	SM800	41	PM980	78	IRZS32
09	SM980	42	PM780		
10	Hi1060	43			
11	SM400	44	PM405		
12		45	PM460		
13		46			

Driver PCB

The Piezoelectric Driver is a PCB designed to mount the Fiber Phase Shifter (PIPS). It features an SMA analog control input capable of modulation speeds up to 1K Hz. The applied voltage is adjustable from 10 to 120 V via a resistance potentiometer on the PCB. A wall-pluggable 12V DC power supply is included. Enclosure is also available at extra.

Warning: do not touch the PCB at any time to void static damage and unpleasant electrical shock.

Driver is \$640