

# Precision Variable Fiber Optical Splitter



The Precision Variable Fiber Optical Splitter maintains a constant splitting ratio between the two output fiber ports, regardless of fluctuations of input power and environment conditions. The splitting ratio can be varied with a control voltage of 0-5V at a fast speed, in which 0V is 100% passing through one port and 5V is 100% passing through another port, respectively. This is achieved by integrating two tap detectors at the two fiber outputs of a 1x2 NanoSpeed™ switch and locking to the ratio using a feedback closed-loop circuit. The splitting is proportional to the 0-5V control signal. The non-mechanical device has passed the most stringent mil-spec and space flight qualifications and is designed for over 20 years of continuous operation. The module comes with a wall-plug 12V power supply.

For 2x2 splitters, the splitting for the two inputs is related but functions simultaneously. One can set the ratio of the first input and then measure the splitting ratio of the second input while turning off the first one.

## Features

- No Moving Parts
- High Reliability
- High Speed
- Precision
- Stable Against Environment Variations

## Specifications

Parameter	Min	Typical	Max	Unit
Central Wavelength	760		2000	nm
Insertion Loss [1]	1260 -1650nm	1.4	2.4	dB
	960 - 1100nm	1.6	2.6	dB
	760 – 960nm	1.8	2.8	dB
Dynamic Range	Single Stage	20	25	dB
	Dual Stage	30	35	dB
Return Loss	45	50		dB
Polarization Extinction Ratio	18		30	dB
Response Time			1	µs
Split Ratio Accuracy	2			%
Attenuation Adjustment Resolution		Continuous		dB
Operating Optical Power (CW)		0.5	10 <sup>[2]</sup>	W
Operating Temperature	-5		70	°C
Storage Temperature	-40		85	°C

**Notes:**

[1]. Excluding connectors. Including the power tapping for feedback control.

[2]: High power version > 2W may have the different arrangement in module package.

**Note:** The specifications provided are for general applications with a cost-effective approach. If you need to narrow or expand the tolerance, coverage, limit, or qualifications, please [\[click this link\]](#):

## Applications

- Laser Power Regulation
- Surge Power Prevention
- Power Balance
- Instrumentation

**Legal notices:** All product information is believed to be accurate and is subject to change without notice. Information contained herein shall legally bind Agiltron only if it is specifically incorporated into the terms and conditions of a sales agreement. Some specific combinations of options may not be available. The user assumes all risks and liability whatsoever in connection with the use of a product or its application.

Rev 06/06/24

# Precision Variable Fiber Optical Splitter

## DATASHEET

### Dimension of PCB (mm)

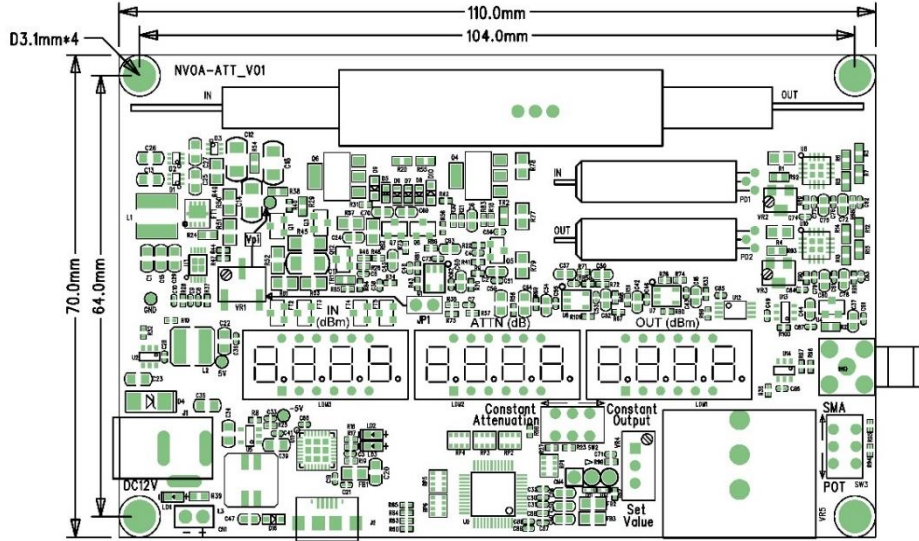

### PCB Details

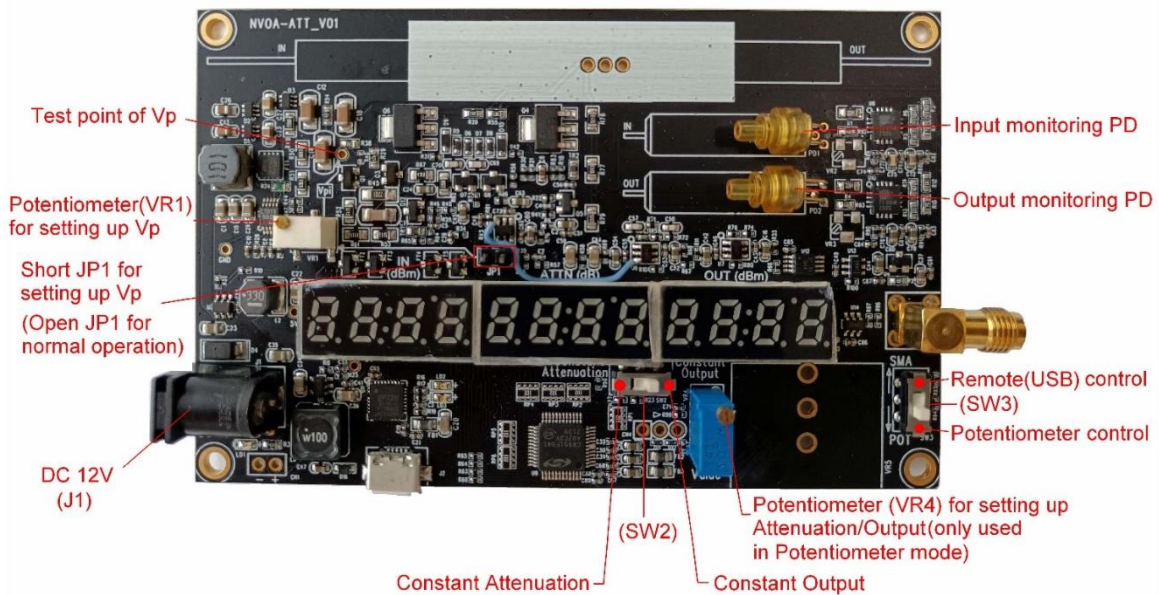

\*Product dimensions may change without notice. This is sometimes required for non-standard specifications.

### Operation Instruction

- Plug in the accompanied power supply.
- Connect to a PC via the USB and load the GUI
- The splitter ratio should vary from maximum to minimum corresponding.
- Once set, the module maintains a constant splitter ratio which is defined as Output1/Output 2, independent of time and environment changes.

# Precision Variable Fiber Optical Splitter

## DATASHEET

### Ordering Information

Prefix	Input Power	Wavelength	Type	Fiber Type	Fiber Cover	Fiber Length	Connector <sup>[1]</sup>
PVST-	0.5W = 11 10W = 10 1W = 01 2W = 02 5W = 05	1060 = 1 2000 = 2 1310 = 3 1480 = 4 1550 = 5 1625 = 6 780 = 7 850 = 8 650 = E 550 = F 400 = G Special = 0	1x2=12 2x2=22 1x3=13 1x4=14 Special=00	SMF-28 = 1 HI1060 = 2 HI780 = 3 PM1550 = 5 PM850 = 8 PM980 = 9 SM1950 = 6 PM1950 = 7 Special = 0	900um tube = 3 Special = 0	0.25m = 1 0.5m = 2 1.0 m = 3 Special = 0	None = 1 FC/PC = 2 FC/APC = 3 SC/PC = 4 SC/APC = 5 ST/PC = 6 LC/PC = 7 LC/UPC = U Special = 0

[1]: High power connector may be available per request, please contact sales.

Special Order

**NOTE:**

PM1550 fiber works well for 1310nm

**Fiber Core Alignment**

Note that the minimum attenuation for these devices depends on excellent core-to-core alignment when the connectors are mated. This is crucial for shorter wavelengths with smaller fiber core diameters that can increase the loss of many decibels above the specification if they are not perfectly aligned. Different vendors' connectors may not mate well with each other, especially for angled APC.

**Fiber Cleanliness**

Fibers with smaller core diameters (<5 μm) must be kept extremely clean, contamination at fiber-fiber interfaces, combined with the high optical power density, can lead to significant optical damage. This type of damage usually requires re-polishing or replacement of the connector.

**Maximum Optical Input Power**

Due to their small fiber core diameters for short wavelength and high photon energies, the damage thresholds for device is substantially reduced than the common 1550nm fiber. To avoid damage to the exposed fiber end faces and internal components, the optical input power should never exceed 20 mW for wavelengths shorter 650nm. We produce a special version to increase the handling by expanding the core side at the fiber ends.

# Precision Variable Fiber Optical Splitter

## DATASHEET

### GUI Instruction

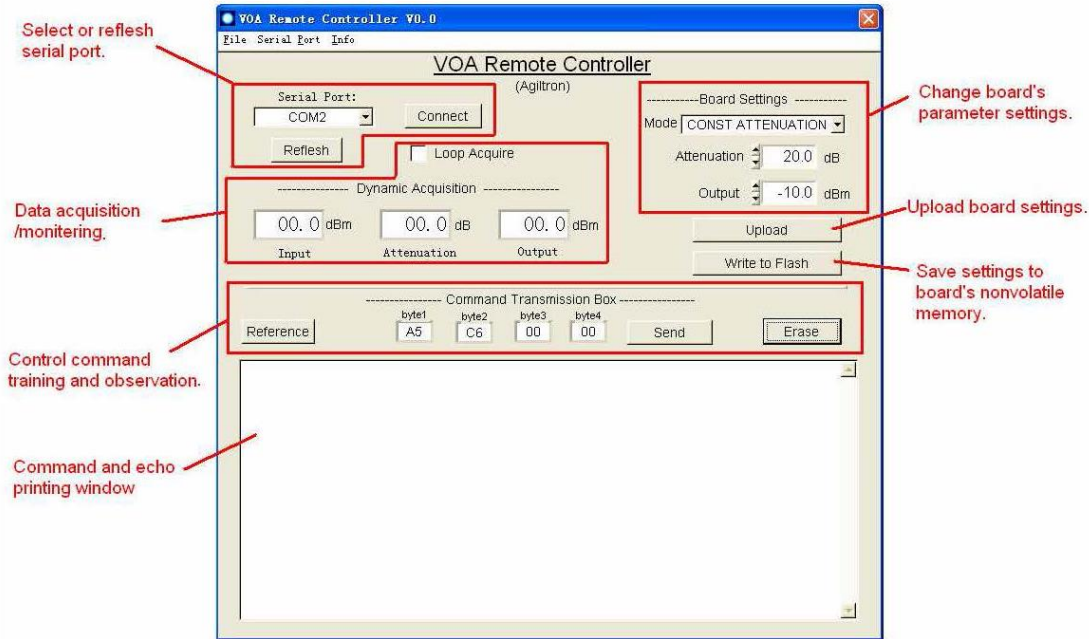

1. Load the software tool “DigiVOA.exe” to the PC, then double-click to open it, and the control above panel will show.
2. Select the serial COM port, which forms the connection, clicking “Connect”.
3. Click the “Upload” button to load the previous setting, however, if the change is not saved after power down, the “Write to Flash” button is provided for downloading these three lines of settings to the board and saving them into the board’s nonvolatile memory.

### Command List

One command string takes 4 bytes; the 1st byte is fixed as 0xA5, the 2nd byte is command type, 3rd and 4th bytes are parameters; refer to the following table for details.

Command	Echo	Description
A5 C0 00 00	5A C0 00 00	Connect
A5 C1 00 00	5A C1 00 00	Disconnect (preserved)
A5 C2 00 yy	5A C2 00 yy	Set Constant Mode. yy = 1: Constant Attenuation; yy = 0: Constant Output
A5 C3 xx xx*	5A C3 xx xx	Set Attenuation dB
A5 C4 xx xx	5A C4 xx xx	Set Output dBm
A5 C5 00 00	5A C5 00 00	Write Settings to Flash
A5 C6 00 00	5A C6 xx xx	Read Input dBm
A5 C7 00 00	5A C7 xx xx	Read Attenuation dBm
A5 C8 00 00	5A C8 xx xx	Read Output dBm
A5 C9 00 00	5A C9 00 yy	Read Constant Mode. yy = 1: Constant Attenuation; yy = 0: Constant Output
A5 CA 00 00	5A CA xx xx	Read Attenuation Setting
A5 CB 00 00	5A CB xx xx	Read Output Setting

\*: Refer to Chapter 6.3 Numerical Format

# Precision Variable Fiber Optical Splitter

## DATASHEET

### Numerical Format

The numeric "xx xx" attached in the command represents dB/dBm, which is a signed 16-bit integer, it ranges in -32,767[0xFFFF] ~ +32,767[0x7FFF], and the most significant bit is the sign flag. It needs to be converted from/to a fixed-point number as a form of +/- ~DDD.D when representing dB/dBm; converting expressions are as follows.

or:

$$\begin{aligned} \text{xx xx (16-bit integer)} &= \text{dB /dBm (fixed point number)} * 10 \\ \text{xx xx (16-bit integer)} / 10 &= \text{dB /dBm (fixed point number)} \end{aligned}$$

Examples:	xx xx (integer)	dB/dBm (fixed-point)
	1200 [0x04B0]	120.0
	999 [0x03E7]	99.9
	10 [0x000A]	1.0
	0 [0x0000]	0.0
	-10 [0x800A]	-1.0
	-100 [0x8064]	-10.0
	-999 [0x83E7]	-99.9