

Ytterbium Doped Fiber Amplifier (1 μ m)

DATASHEET

BUY NOW 



Agiltron Ytterbium-doped fiber amplifier (EDFA) provides cost-effective solutions for high-power optical amplification. The product has the advantages of high reliability, high power output, high gain, and low noise. Two configurations are available: A pre-amplifier for small optical signal amplification and a Booster amplifier for maximum output power. We make both random polarization and polarization maintain versions. It has several package configuration choices. A Benchtop unit that is preset at the highest gain is suited for laboratory use. The Benchtop has a computer control interface and GUI. The compact module is suited for system integration with the universal control interface. The pluggable and the associated host net-control rack are standardized for local network build-out. Customer configurations are available with an NRE fee.

The EDFA has isolators on both input and output.

These Erbium-Doped Fiber Amplifiers (EDFAs) are engineered for a long operational lifespan, typically designed to function reliably for over 10 years. This durability is achieved through high-quality components and robust manufacturing processes. The design considerations include thermal management, component selection, and rigorous testing to maximize the amplifier's longevity and efficiency.

Features

- Low Noise
- High Output at 27dBm
- High stability
- High Reliability
- Customizable

Applications

- BOTDR
- OTDR
- LiDAR
- Fiber sensing

Specifications

Parameter	Min	Typical	Max	Unit
Wavelength	1025		1075	nm
Saturated Output Power ^[1]	19			dBm
Power Conversion Efficiency ^[2]	8		11	
Gain Range ^[3]	22			dB
Noise Index			8	dB
Gain Flatness		3		dB
Polarization Dependent Gain ^[4]			0.3	dB
Polarization Mode Dispersion ^[4]		0.5		
Polarization Extinction Ratio ^[5]	18		20	dB
Input/output Isolation	20			dB
Output Stability (8hrs)		0.1	0.2	dB
Working Temperature ^[6]	-30		70	°C
Storage Temperature	-40		85	°C
Fiber Type	Hi1060 for regular, PM980 for PM			
Power Supply	DC +5V/GND			
Communication	>20dBm	RS232		
	<20dBm	USB		

Notes:

- [1] Maximum optical output power. For Booster type only
 - [2] Define as the ratio of Electrical Input Power/Optical Output Power
 - [3] Amplification. Output power = Gain X Input power. For weak signals, buy a preamplifier
 - [4] Random polarization version only
 - [5] Polarization Maintaining only
 - [6] The regular range is -5 to 40°C, for extended range requires additional cost
- * Preamplifier output power is limited to 25dBm

Note: The specifications provided are for general applications with a cost-effective approach. If you need to narrow or expand the tolerance, coverage, limit, or qualifications, please [\[click this link\]](#):

Legal notices: All product information is believed to be accurate and is subject to change without notice. Information contained herein shall legally bind Agiltron only if it is specifically incorporated into the terms and conditions of a sales agreement. Some specific combinations of options may not be available. The user assumes all risks and liability whatsoever in connection with the use of a product or its application.

Rev 08/29/24

Ytterbium Doped Fiber Amplifier (1 μ m)

DATASHEET

Function Diagram

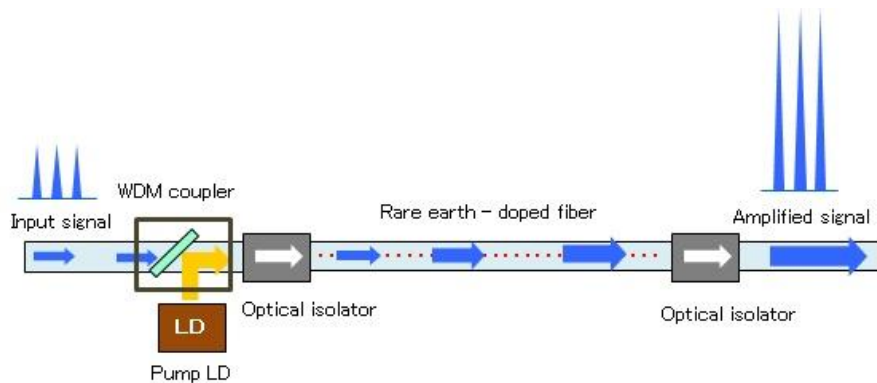

Package Choices



Component



Benchtop



Net-Control Rack

Ytterbium Doped Fiber Amplifier (1 μ m)

DATASHEET

Mechanical Dimension (33dBm)

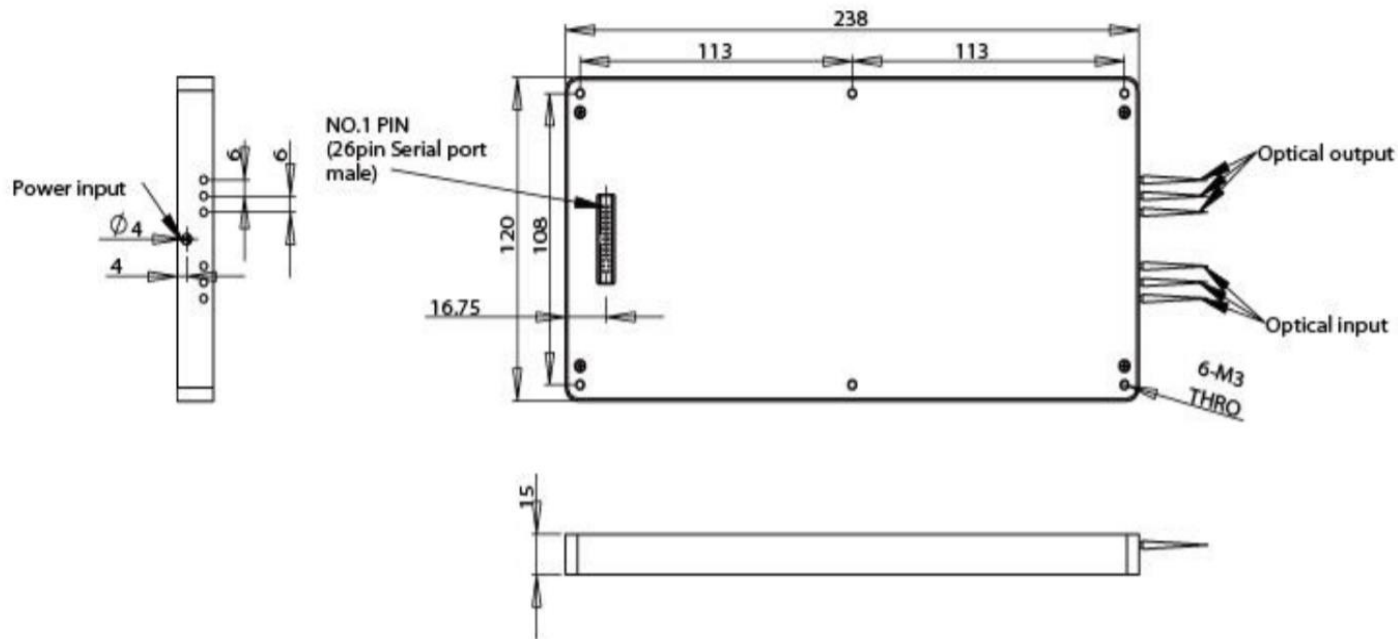

*Product dimensions may change without notice. This is sometimes required for non-standard specifications.

Ordering Information

Prefix	Type	Wavelength	Power ^[1]	Output Channel	Polarization	Package	Cable Type	Fiber Length ^[3]	Connector ^[4]	Low Temperature	High Temperature
YTFA-	Standard = 1 Special = 2	1025-1075nm = 1 Special = 0	17 dBm ^[2] = 1 22 dBm = 2 25 dBm = 3 35 dBm = 4 Special = 0	One = 1 Two = 2 Three = 3 Four = 4	Random = 1 Maintain = 2	Component = 1 Benchtop = 2 Special = 0	Bare fiber = 1 0.9mm tube = 3 Special = 0	0.25m = 1 0.5m = 2 1.0m = 3 Special = 0	None = 1 FC/PC = 2 FC/APC = 3 SC/PC = 4 SC/APC = 5 LC/PC = 7 Duplex LC/PC = 8 LC/APC = A LC/UPC = U Special = 0	-5°C = 1 -30°C = 2 Special = 0	40°C = 1 70°C = 2 Special = 0

[1]. For Booster, Power means maximum output power. For Preamp, Power means maximum amplification gain.

[2]. This has a small package without power adjustment capability for lower cost

[3]. For >1W modules, the fiber cables extrude out of the front.

[4]. Regular connector only rated to 0.5W and will burn at higher power. We make a special beam expanded connector to handle up to 5W

NOTE:

- ☐ Preamplifier output power is limited to 25dBm

Ytterbium Doped Fiber Amplifier (1 μ m)



DATASHEET

Q&A About Fiber Optical Amplifier

Q: Can this amplifier pulsed signals?

A: It has been tested to amplify up to 100GHz digital data.

Q: Can this amplifier WDM signals?

A: It has been tested to amplify signals with DWDM wavelength spacing.

Q: Can this amplifier has a flat wavelength response?

A: Yes, by put fluttering gain filters, that is an extra cost.

Q: If one puts a small signal into it, can it be amplified to the maximum output power indicated on the spec?

A: The amplifier is set as an analog mode whose output signal strength is approximately proportional to the input strength. It has a certain gain of about 40dB. There are two types: one is a preamplifier and a booster. One can use a preamplifier before the booster for weak signals, as done in electronic amplifiers.

Q: We have an existing amplifier. Can you duplicate it?

A: Yes, we can produce it with a seamless software interface.

Modes Description

The EDFAs have both ACC mode - automatic current control or constant current control and APC mode - automatic power control settable via GUI. In the ACC mode, the pump laser's current is set by the user and automatically locked by the EDFA to achieve a constant pumping current. The EDFA's output power is proportional to the input power and has output even though the input signal is weak. In the APC mode, the user sets the output power, and the EDFA automatically maintains the output constant in a feedback laser pump control way. When the input optical power fluctuates, the APC mode minimizes the fluctuation of the output power and is suitable for power type and line type EDFA.

Application Notes

Fiber Core Alignment

Note that the minimum attenuation for these devices depends on excellent core-to-core alignment when the connectors are mated. This is crucial for shorter wavelengths with smaller fiber core diameters that can increase the loss of many decibels above the specification if they are not perfectly aligned. Different vendors' connectors may not mate well with each other, especially for angled APC.

Fiber Cleanliness

Fibers with smaller core diameters (<5 μ m) must be kept extremely clean, contamination at fiber-fiber interfaces, combined with the high optical power density, can lead to significant optical damage. This type of damage usually requires re-polishing or replacement of the connector.

Maximum Optical Input Power

Due to their small fiber core diameters for short wavelength and high photon energies, the damage thresholds for device is substantially reduced than the common 1550nm fiber. To avoid damage to the exposed fiber end faces and internal components, the optical input power should never exceed 20 mW for wavelengths shorter 650nm. We produce a special version to increase the handling by expanding the core side at the fiber ends.

Ytterbium Doped Fiber Amplifier (1 μ m)



DATASHEET

Typical Spectrums

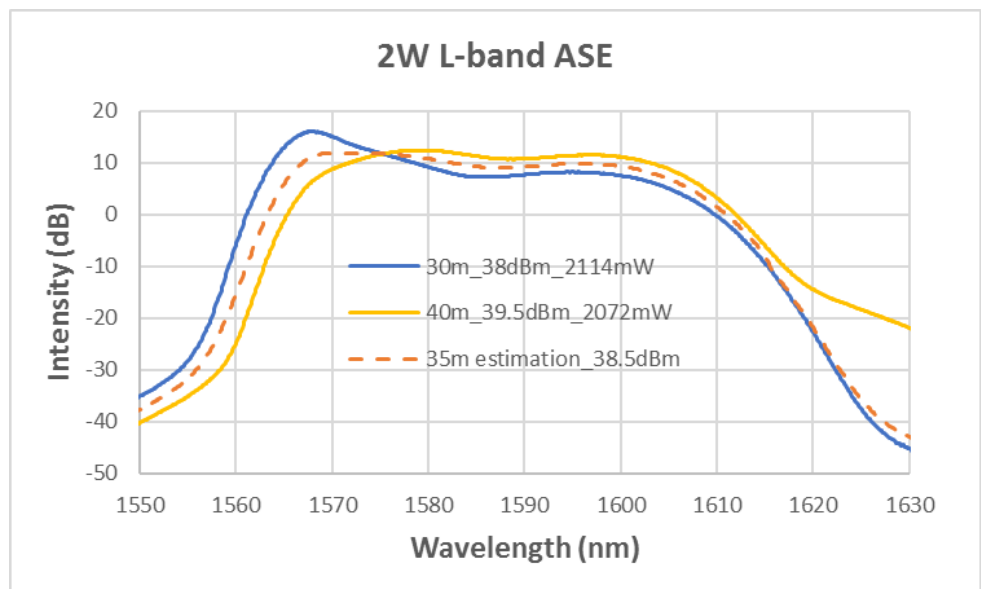
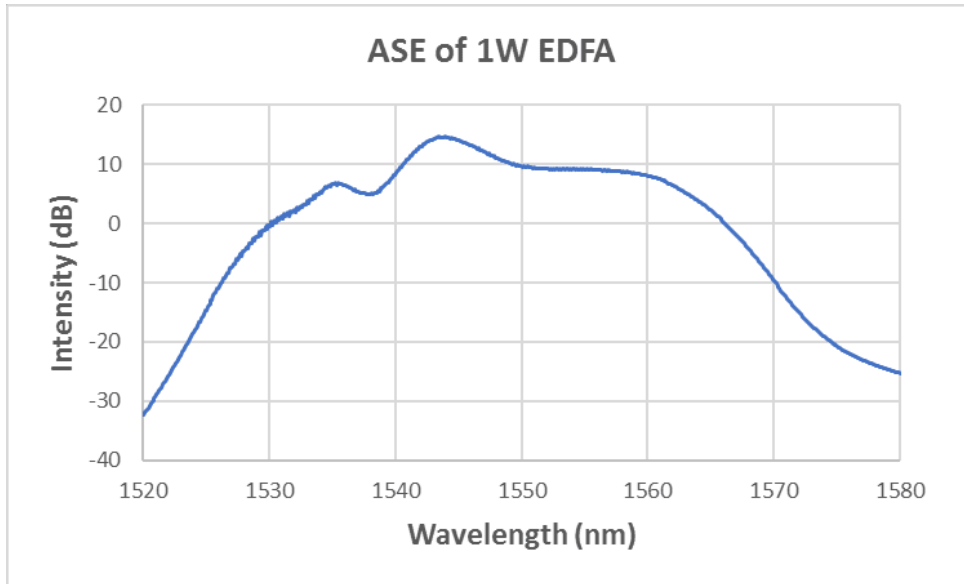

Ytterbium Doped Fiber Amplifier (1 μ m)



DATASHEET

Control GUI

EDFA GUI V3.0

AGILTRON INC

Choose Device Model
EDFA-L

Connect to Amplifier
COM7 Refresh Disconnect

Monitor Status
Opt.IN -0.34 dBm
Opt.Out 15 dBm
BIAS-1 417 mA
CoolCurr-1 0 mA
LaserTemp-1 26.2 °C
Modul Temp 25.1 °C
PumpPower 21.67 dBm
Power Voltage 4.93 V
GAIN 15.31 dB
ALARM: No Alarms
Model: EDFA-20dBm
SN: 220728001

Set Amplifier Parameters
Check Settings Pump ON Pump OFF
Control Mode: Power control Set Power(dBm) 15 Set Set Current(mA) 600 Set
Set Gain(dB) 23 Set

Command Log
Port connected
Get Sn/Model Success
Power Control Mode: Success
Check Settings: Success

Threshold settings
Module Temp Threshold -5 - 55 °C Set
Pump Temp Threshold 0 - 40 °C Set
Pump Current Threshold 1200 mA Set
Input Power LOS Threshold -33 dBm Set
Output Power LOS Threshold -8 dBm Set
No Optical Power Threshold -33 dBm Set