

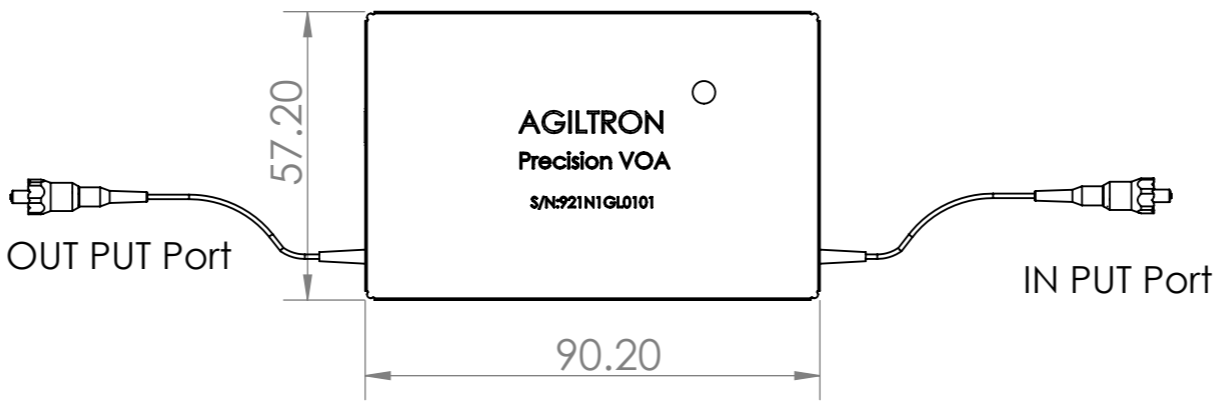

8 7 6 5 4 3 2 1

F
E
D
C
B
A

F
E
D
C
B
A

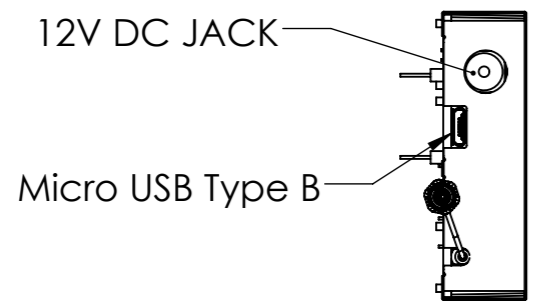
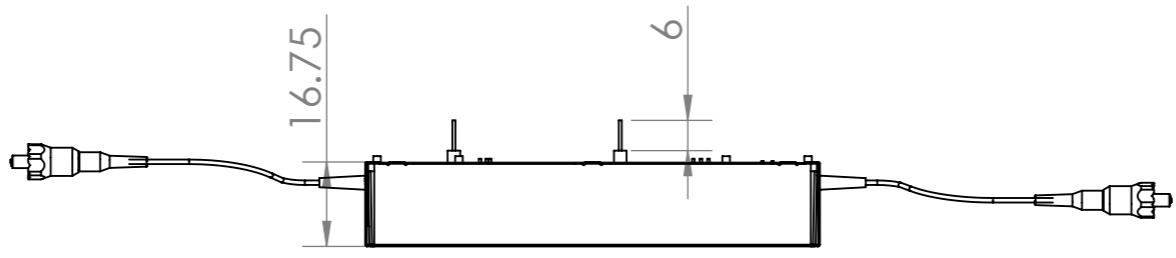
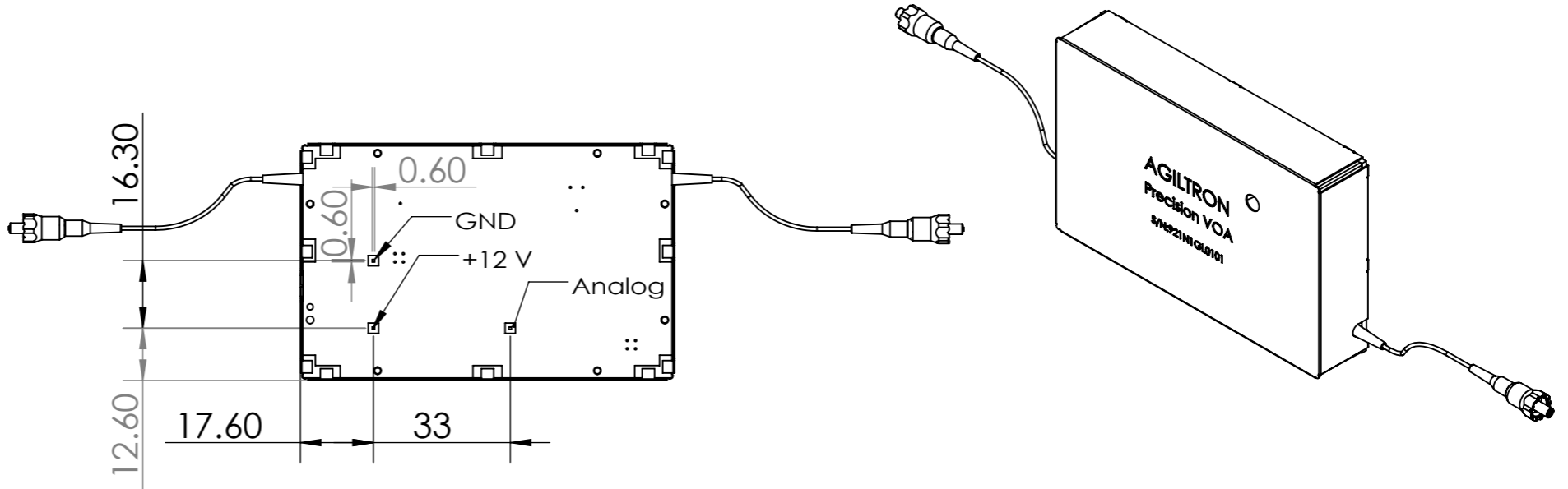

UNLESS OTHERWISE SPECIFIED:

<p>1. DO NOT SCALE DRAWING. 2. INTERPRET PER ASME Y14.100M. 3. DIMENSIONS ARE IN METRIC. 4. SURFACE TEXTURE SHALL BE 125 5. REMOVE BURRS AND SHARP EDGES 6. DIMENSIONS APPLY BEFORE PLATING OR CONVERSION COATING. 7. PARENTHETICAL DATA IS FOR REFERENCE ONLY</p>	TOLERANCES:				NAME: _____ DATE: _____ DO NOT SCALE DRAWING  TITLE: Piezo VOA final drawing DWG NO.: _____ SCALE: 1:1 SHEET 1 OF 1	
	ON ALL HOLE DIAMETERS					DRAWN: _____ APPV'D: _____ MFG: _____ Q.A: _____ MATERIAL: _____ WEIGHT: _____
	Under 1.0	+0.05 -0.01	25 THRU 50	+0.2 -0.1		
	1.0 THRU 5.0	+0.1 -0.025	>50	+0.25 -0.1		
		ON ANGULAR DIMENSIONS:				
ON DECIMAL DIMENSIONS:	MACHINED $\pm 0.30'$					
.XXX ± 0.010	LOCATING $\pm 0.30'$					
.XX ± 0.03	FORMED $\pm 0.5'$					
.X ± 0.1	CHANFERS $\pm 0.5'$					

8 7 6 5 4 3 2 1